



What We Do : Speedofer Components manufactures Soft Ferrite Cores in forms and shapes of Drum, EDR, EE, EER, EFD, EI, ELP, EP, EPC, ER,ET, ETD, EV, I, Planer, Pot, PQ, Ring (Toroidal), RM, UT, UU & etc. geometries that composed from FeMnZn (Iron, Manganese & Zinc). These Ferrites are used in making Transformers, Inductors, Chokes and Ferrite Beads that apply in powering any electronics circuits.

What We Believe : Speedofer Components Believing that Research & Development is the only way forward for the products we manufacture and substantially invested in state-of-the-art Swiss made equipment lines.

Who We Are : Speedofer Components was found in 2007 by the most experienced professionals in Soft Ferrite Cores in India. Speedofer also has high skilled manpower with more than THREE DECADES of experience in the field of Ferrite Cores. Our organization work to the standards of Business Excellence and are fully committed to the principle of consistent and continuous improvement at all levels of our organization. This involves everyone, including our Suppliers and forms the basis for successful relationships.

Customized Products: Speedofer Components also sales NiZn (Nickel Zinc), Iron Powder, MPP (Molypermalloy Powder), Sendust composed and customized Ferrite Cores for special applications. Exports: Speedofer Components generates about 5% of total revenues from exports.

Employees : 50~100

Application : Consumer Electronics, EMI, EV (Electric Vehicle) , LED Lighting, Conventional Lighting, Solar Energy, Telecommunications and Power Distribution.

Plant Capacity : 150 Tons (60 Million pieces per month).

Why Speedofer : Best Quality, Competitive Price, Product Customization, Quick Delivery & Aftersales Service.

System Certifications : QMS ISO 9001:2015, EMS ISO14001:2015, OHSAS ISO 45001:2018

System Certifications : RoHS Directive 2011/65/EU, REACH

D&B D-U-N-S Number : 67-738-4917

Speedofer Components Pvt. Ltd.		
	System Compliance	ISO 9001:2015 Quality Management System
	Clause & Description	4.2.1, Quality Policy
	Document No	SCPL-QMS-MR-CP-02
	Date	21 st September 2021
<p>Quality Policy</p> <p>We, at Speedofer Components Pvt. Ltd. are committed to manufacture products as per the requirements of our Customers and are also committed to give the best after sales service through continual improvement in Quality Management Systems.</p>  <p><small>S S Randhava The Managing Director</small></p>		



Order	Content Description	Page No
1	Front Cover	1
2	Company Profile in Brief	2
3	Catalogue Index	3
4	Material Characteristics Index (MnZn)	4-5
5	SFP4 Material Characteristics	6
6	SFP97 Material Characteristics	7
7	SFP95 Material Characteristics	8
8	SFP92 Material Characteristics	9
9	SFP33 Material Characteristics	10
10	SFP48 Material Characteristics	11
11	SFP49 Material Characteristics	12
12	SFA05 Material Characteristics	13
13	SFA07 Material Characteristics	14
14	SFA10 Material Characteristics	15
15	SFA12 Material Characteristics	16
16	Drum Cores	17
17	EDR Cores	18-19
18	EE Cores	20-21
19	EFD Cores	22-23
20	EI Cores	22-23
21	EP Cores	24-25
22	EPC Cores	24-25
23	ER Cores	26-27
24	EQ Cores	26-27
25	ET Cores	28-29
26	ETD Cores	28-29
27	I Cores	30-31
28	Pot Cores	30-31
29	PQ Cores	32-33
30	RM Cores	34-35
31	Toroidal Cores	36-39
32	UT Cores	40-41
33	UU Cores	40-41
34	Definitions & Formulas	42-45
35	Certifications & Back Cover Content	46
36	Speedofer Senior Management	47

Material Properties	Symbol	Unit	Measuring Conditions			SFP4	SFP97
			Freq.	Flux den.	Temp.		
Initial Permeability	μ_i		10kHz	0.25mT	25°C	2300±25%	2500±25%
Power Loss	Pv	kW/m ³	25kHz	200mT	25 °C	105	125
					100°C	55	50
			100kHz	200mT	25 °C	600	600
					100°C	410	250
			300kHz	100mT	25 °C	660	820
					100°C	430	500
			500kHz	50mT	25 °C	380	400
					100°C	330	300
Saturation Flux Density	Bms	mT	10KHz	H=1200A/m	25°C	510	530
					100°C	390	420
Remanence	Brms	mT	10KHz	H=1200A/m	25°C	95	180
					100°C	55	60
Coercivity	Hc	A/m	10kHz	H=1200A/m	25°C	14	13
					100°C	8.8	6
Relative Loss Factor	tan δ / μ_i	10 ⁻⁶	10KHz	<0.25mT	25°C	-	-
			100kHz		25°C	-	-
Hysteresis Material Constant	η_B	10 ⁻⁶ /mT	10KHz	1.5-3.0mT	25°C	<1.2	<1
Disaccommodation Factor	D _F	10 ⁻⁶	10KHz	< 0.25mT	25°C	<2.0	<2.0
Curie Temperature	T _c	°C	-	-	-	≥220	>230
Resistivity	ρ	Ω m	-	-	-	6.5	4
Density	d	g/cm ³	-	-	-	4.8	4.9

SFP95	SFP92	SFP33	SFP48	SFP49	SFA05	SFA07	SFA10	SFA12
3300±25%	1700±25%	750±25%	2500±25%	1500±25%	5000±25%	7000±25%	10000±30%	12000±30%
-	-	-	-	-	-	-	-	-
-	-	-	-	-	-	-	-	-
350	750	-	-	-	-	-	-	-
300	400	-	-	-	-	-	-	-
-	-	-	-	410	-	-	-	-
410	-	-	-	370	-	-	-	-
-	450	-	-	200	-	-	-	-
250	230	-	-	100	-	-	-	-
530	540	500	450	490	440	400	410	380
410	460	410	320	400	300	200	210	180
85	280	400	180	215	80	150	140	130
60	50	330	150	125	90	110	110	110
9.5	14	25	18	35	-	-	-	-
6.5	8	20	12	30	-	-	-	-
-	-	<60	<7	-	<4	<8	<10	<10
-	-	<20	<3	-	<15	<30	<60	<60
<1.2	<1.0	<2.5 (100kHz)	<0.6	<1.0	<0.8	<1.2	<0.5	<0.5
<2.0	<2.0	8	-	<2.0	<2.0	<2.0	<2.0	<2.0
≥215	≥280	≥250	≥170	≥250	≥140	≥130	≥130	≥110
6	3	2	7.5	12	0.2	0.35	0.15	0.12
4.9	4.9	4.7	4.7	4.85	4.85	4.9	4.9	4.9



Material Properties	Symbol	Unit	Measuring Conditions			SFP4
			Freq.	Flux den.	Temp.	
Initial Permeability	μ_i		10kHz	0.25mT	25°C	2300±25%
Power Loss	Pv	kW/m ³	25kHz	200mT	25 °C	105
					100°C	55
			100kHz	200mT	25 °C	600
					100°C	410
			300kHz	100mT	25 °C	660
					100°C	430
500kHz	50mT	25 °C	380			
		100°C	330			
Saturation Flux Density	Bms	mT	10KHz	H=1200A/m	25°C	490
					100°C	390
Remanence	Brms	mT	10KHz	H=1200A/m	25°C	95
					100°C	55
Coercivity	Hc	A/m	10kHz	H=1200A/m	25°C	14
					100°C	8.8
Hysteresis Material Constant	η_B	10 ⁻⁶ /mT	10KHz	1.5-3.0mT	25°C	<1.2
Disaccommodation Factor	D _F	10 ⁻⁶	10KHz	< 0.25mT	25°C	<2.0
Curie Temperature	T _c	°C				≥220
Resistivity	ρ	Ω m				6.5
Density	d	g/cm ³				4.8

Note: Material characteristics are typical for a toroid core.
 Product specification will differ from these data due to the influence of geometry and size.

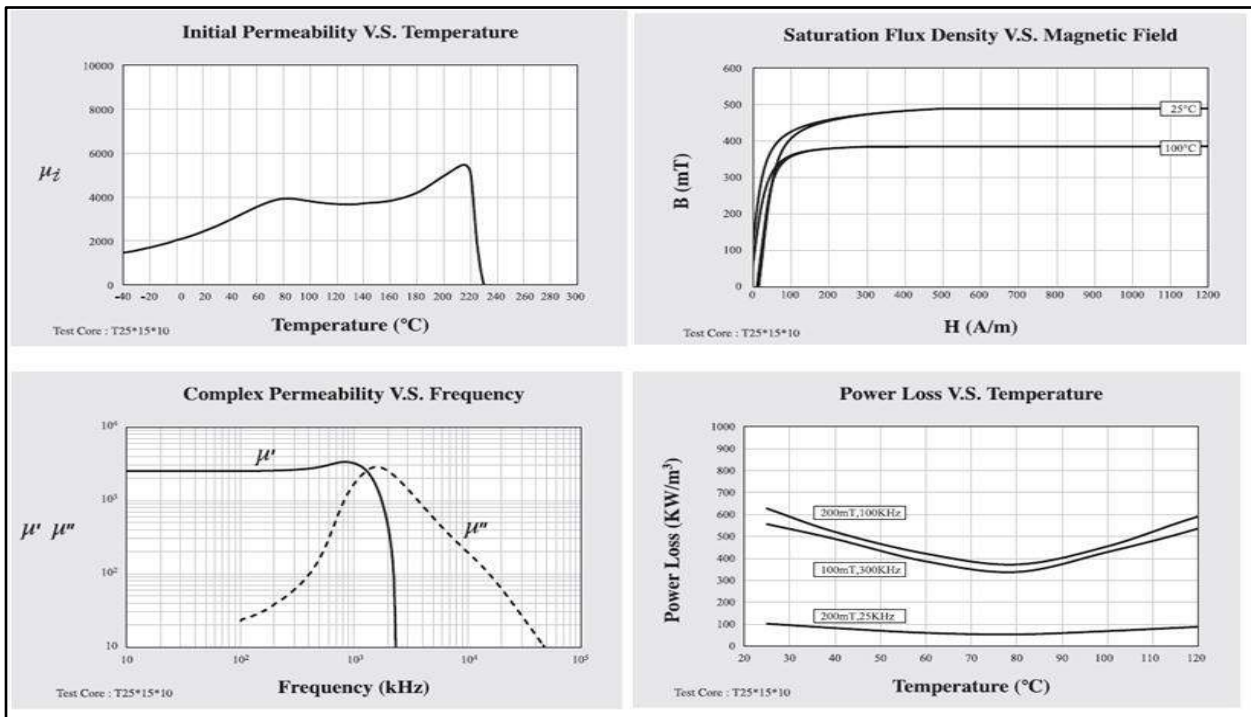



Material Properties	Symbol	Unit	Measuring Conditions			SFP97
			Freq.	Flux den.	Temp.	
Initial Permeability	μ_i		10kHz	0.25mT	25°C	2500±25%
Power Loss	Pv	kW/m ³	25kHz	200mT	25 °C	125
					100°C	50
			100kHz	200mT	25 °C	600
					100°C	250
			300kHz	100mT	25 °C	820
					100°C	500
500kHz	50mT	25 °C	400			
		100°C	300			
Saturation Flux Density	Bms	mT	10KHz	H=1200A/m	25°C	530
					100°C	420
Remanence	Brms	mT	10KHz	H=1200A/m	25°C	180
					100°C	60
Coercivity	Hc	A/m	10kHz	H=1200A/m	25°C	13
					100°C	6
Hysteresis Material Constant	η_B	10 ⁻⁶ /mT	10KHz	1.5-3.0mT	25°C	<1
Disaccommodation Factor	D _F	10 ⁻⁶	10KHz	< 0.25mT	25°C	<2.0
Curie Temperature	T _c	°C				>230
Resistivity	ρ	Ω m				4
Density	d	g/cm ³				4.9

Note: Material characteristics are typical for a toroid core.
Product specification will differ from these data due to the influence of geometry and size.

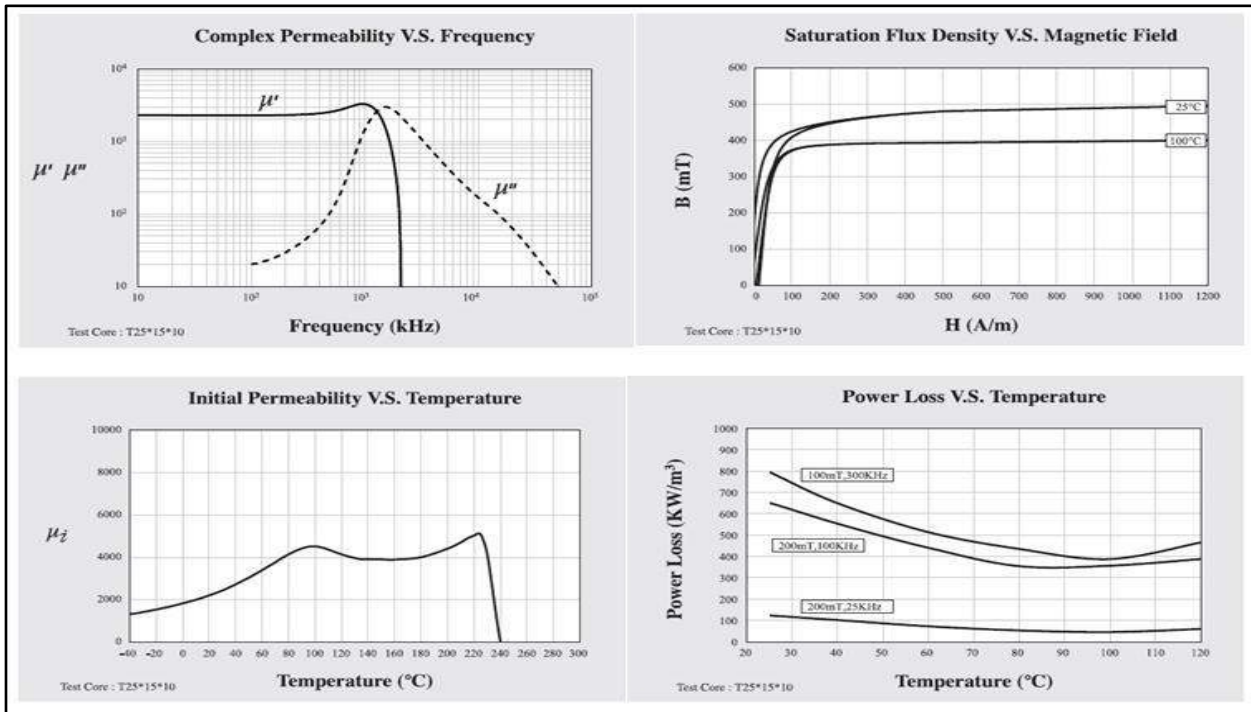



Material Properties	Symbol	Unit	Measuring Conditions			SFP95
			Freq.	Flux den.	Temp.	
Initial Permeability	μ_i		10kHz	0.25mT	25°C	3300±25%
Power Loss	Pv	kW/m ³	25kHz	200mT	25 °C	-
					100°C	-
			100kHz	200mT	25 °C	350
					100°C	300
			300kHz	100mT	25 °C	440
					100°C	400
500kHz	50mT	25 °C	-			
		100°C	250			
Saturation Flux Density	Bms	mT	10KHz	H=1200A/m	25°C	530
					100°C	410
Remanence	Brms	mT	10KHz	H=1200A/m	25°C	85
					100°C	60
Coercivity	Hc	A/m	10kHz	H=1200A/m	25°C	9.5
					100°C	6.5
Hysteresis Material Constant	η_B	10 ⁻⁶ /mT	10KHz	1.5-3.0mT	25°C	<0.6
Disaccommodation Factor	D _F	10 ⁻⁶	10KHz	< 0.25mT	25°C	<1
Curie Temperature	T _c	°C				≥215
Resistivity	ρ	Ω m				6
Density	d	g/cm ³				4.9

Note: Material characteristics are typical for a toroid core.
 Product specification will differ from these data due to the influence of geometry and size.

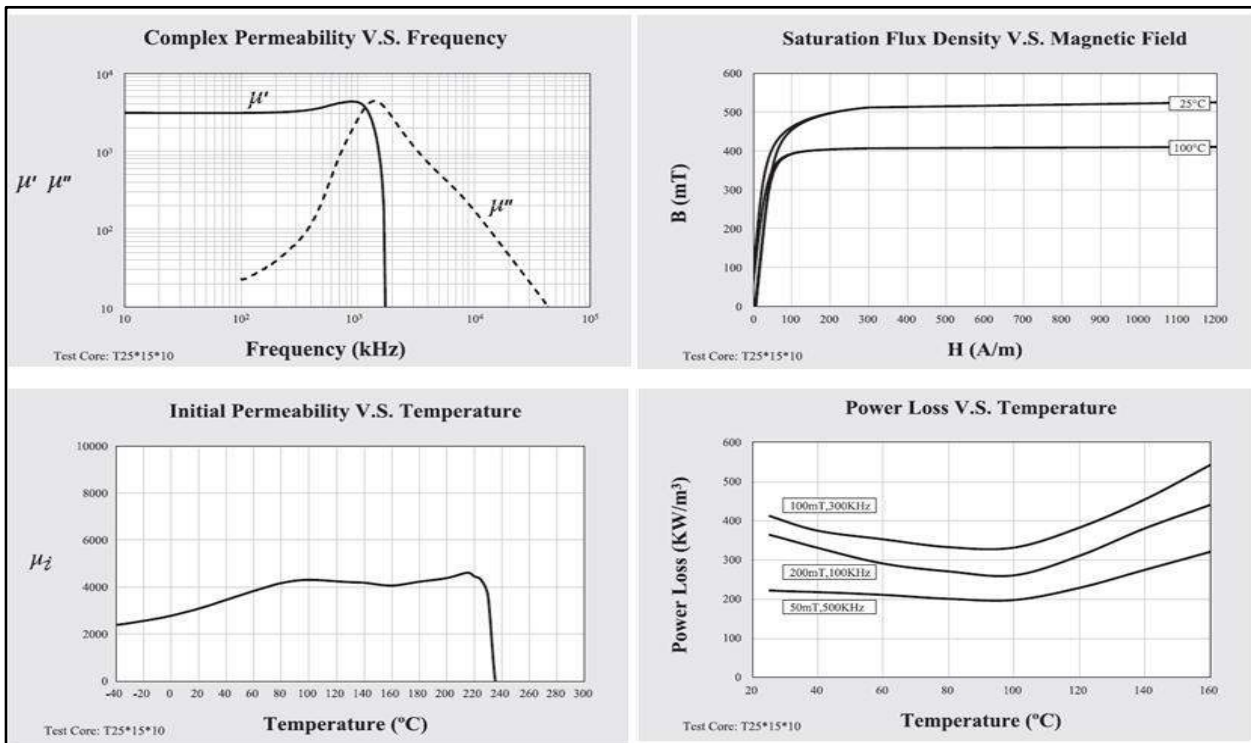

Material Properties	Symbol	Unit	Measuring Conditions			SFP92
			Freq.	Flux den.	Temp.	
Initial Permeability	μ_i		10kHz	0.25mT	25°C	1700±25%
Power Loss	Pv	kW/m ³	25kHz	200mT	25 °C	-
					100°C	-
			100kHz	200mT	25 °C	750
					100°C	400
			300kHz	100mT	25 °C	-
					100°C	-
500kHz	50mT	25 °C	450			
		100°C	230			
Saturation Flux Density	Bms	mT	10KHz	H=1200A/m	25°C	540
					100°C	460
Remanence	Brms	mT	10KHz	H=1200A/m	25°C	280
					100°C	50
Coercivity	Hc	A/m	10kHz	H=1200A/m	25°C	14
					100°C	8
Relative Loss Factor	tan δ / μ_i	10 ⁻⁶	10KHz	<0.25mT	25°C	-
			100kHz		25°C	-
Hysteresis Material Constant	η_B	10 ⁻⁶ /mT	10KHz	1.5-3.0mT	25°C	<1.0
Disaccommodation Factor	D _F	10 ⁻⁶	10KHz	< 0.25mT	25°C	<2.0
Curie Temperature	T _c	°C	-	-	-	≥280
Resistivity	ρ	Ω m	-	-	-	3
Density	d	g/cm ³	-	-	-	4.9

Note: Material characteristics are typical for a toroid core.
 Product specification will differ from these data due to the influence of geometry and size.

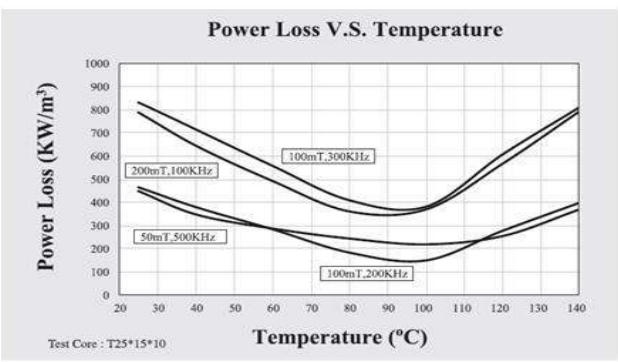
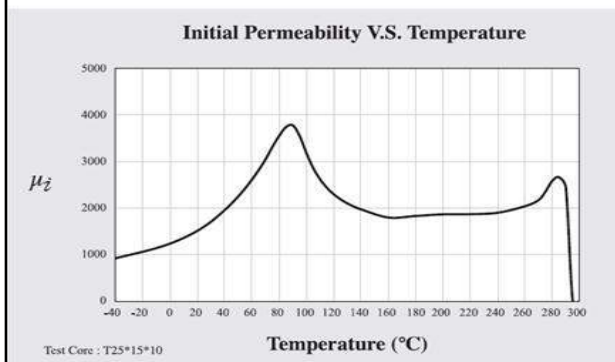
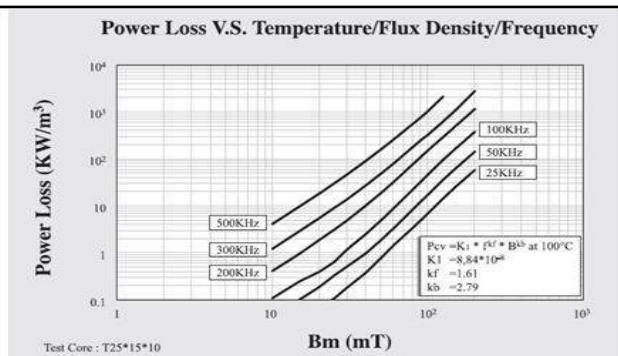
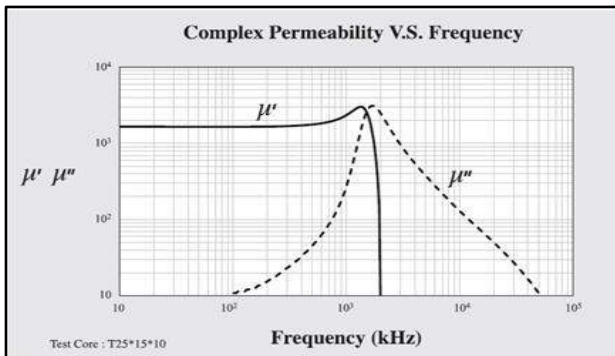



Material Properties	Symbol	Unit	Measuring Conditions			SFP33
			Freq.	Flux den.	Temp.	
Initial Permeability	μ_i		10kHz	0.25mT	25°C	750±25%
Power Loss	Pv	kW/m ³	25kHz	200mT	25 °C	-
					100°C	-
			100kHz	200mT	25 °C	-
					100°C	-
			300kHz	100mT	25 °C	-
					100°C	-
500kHz	50mT	25 °C	-			
		100°C	-			
Saturation Flux Density	Bms	mT	10KHz	H=1200A/m	25°C	500
					100°C	410
Remanence	Brms	mT	10KHz	H=1200A/m	25°C	400
					100°C	330
Coercivity	Hc	A/m	10kHz	H=1200A/m	25°C	25
					100°C	20
Relative Loss Factor	$\tan\delta / \mu_i$	10 ⁻⁶	10KHz	<0.25mT	25°C	<60
			100kHz		25°C	<20
Hysteresis Material Constant	η_B	10 ⁻⁶ /mT	10KHz	1.5-3.0mT	25°C	<2.5 (100kHz)
Disaccommodation Factor	D _F	10 ⁻⁶	10KHz	< 0.25mT	25°C	8
Curie Temperature	T _c	°C				≥250
Resistivity	ρ	Ω m				2
Density	d	g/cm ³				4.7

Note: Material characteristics are typical for a toroid core.
 Product specification will differ from these data due to the influence of geometry and size.

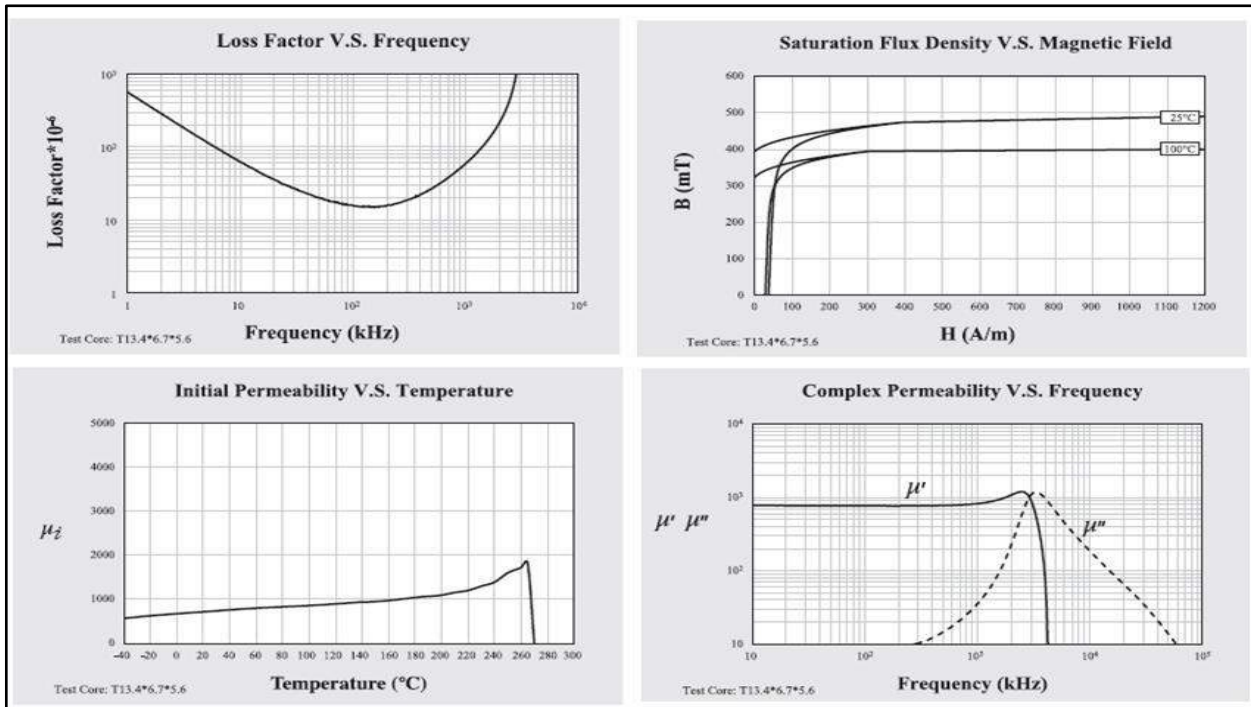



Material Properties	Symbol	Unit	Measuring Conditions			SFP48
			Freq.	Flux den.	Temp.	
Initial Permeability	μ_i		10kHz	0.25mT	25°C	2500±25%
Power Loss	Pv	kW/m ³	25kHz	200mT	25 °C	-
					100°C	-
			100kHz	200mT	25 °C	-
					100°C	-
			300kHz	100mT	25 °C	-
100°C	-					
500kHz	50mT	25 °C	-			
		100°C	-			
Saturation Flux Density	Bms	mT	10KHz	H=1200A/m	25°C	450
					100°C	320
Remanence	Brms	mT	10KHz	H=1200A/m	25°C	180
					100°C	150
Coercivity	Hc	A/m	10kHz	H=1200A/m	25°C	18
					100°C	12
Relative Loss Factor	tan δ / μ_i	10 ⁻⁶	10KHz	<0.25mT	25°C	<7
			100kHz		25°C	<3
Hysteresis Material Constant	η_B	10 ⁻⁶ /mT	10KHz	1.5-3.0mT	25°C	<0.6
Disaccommodation Factor	D _F	10 ⁻⁶	10KHz	< 0.25mT	25°C	-
Curie Temperature	T _c	°C				≥170
Resistivity	ρ	Ω m				7.5
Density	d	g/cm ³				4.7

Note: Material characteristics are typical for a toroid core.
 Product specification will differ from these data due to the influence of geometry and size.

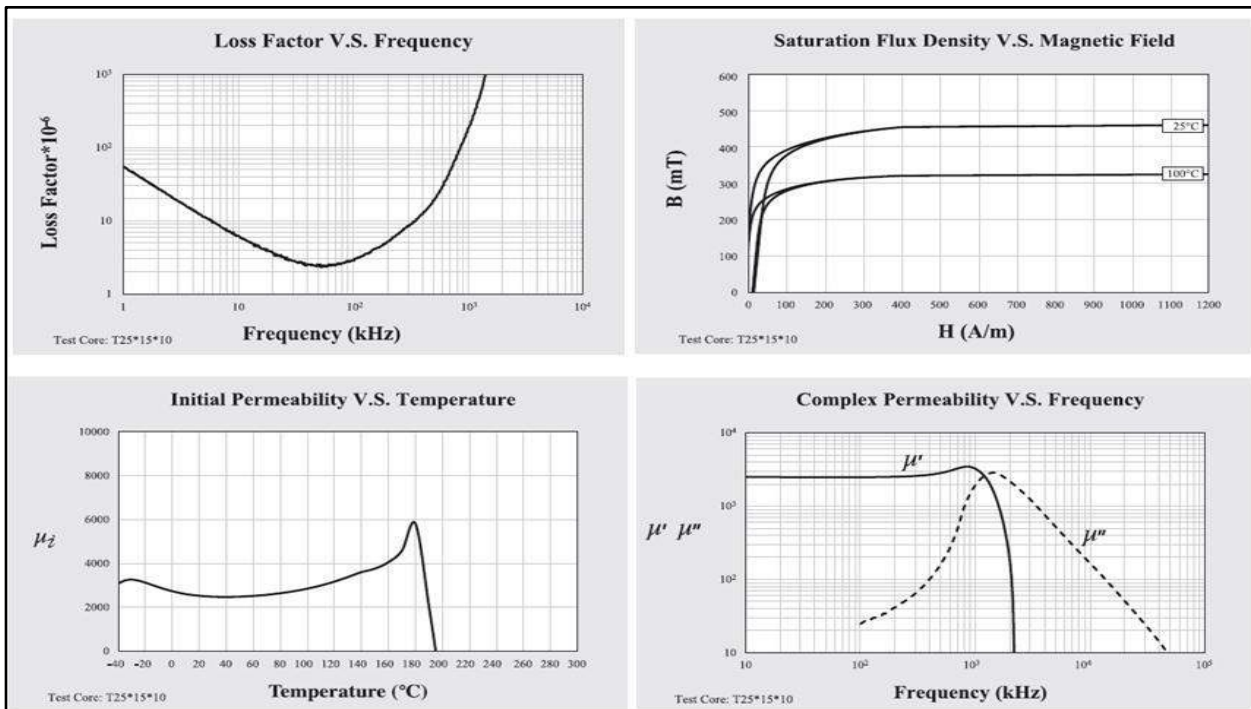



Material Properties	Symbol	Unit	Measuring Conditions			SFP49
			Freq.	Flux den.	Temp.	
Initial Permeability	μ_i		10kHz	0.25mT	25°C	1500±25%
Power Loss	Pv	kW/m ³	25kHz	200mT	25 °C	-
					100°C	-
			100kHz	200mT	25 °C	-
					100°C	-
			300kHz	100mT	25 °C	410
					100°C	370
			500kHz	50mT	25 °C	200
					100°C	100
1000kHz	50mT	25 °C	-			
		100°C	550			
Saturation Flux Density	Bms	mT	10KHz	H=1200A/m	25°C	490
					100°C	400
Remanence	Brms	mT	10KHz	H=1200A/m	25°C	215
					100°C	125
Coercivity	Hc	A/m	10kHz	H=1200A/m	25°C	35
					100°C	30
Hysteresis Material Constant	η_B	10 ⁻⁶ /mT	10KHz	1.5-3.0mT	25°C	<1.0
Disaccommodation Factor	D _F	10 ⁻⁶	10KHz	< 0.25mT	25°C	<2.0
Curie Temperature	T _c	°C				≥250
Resistivity	ρ	Ω m				12
Density	d	g/cm ³				4.85

Note: Material characteristics are typical for a toroid core.
 Product specification will differ from these data due to the influence of geometry and size.

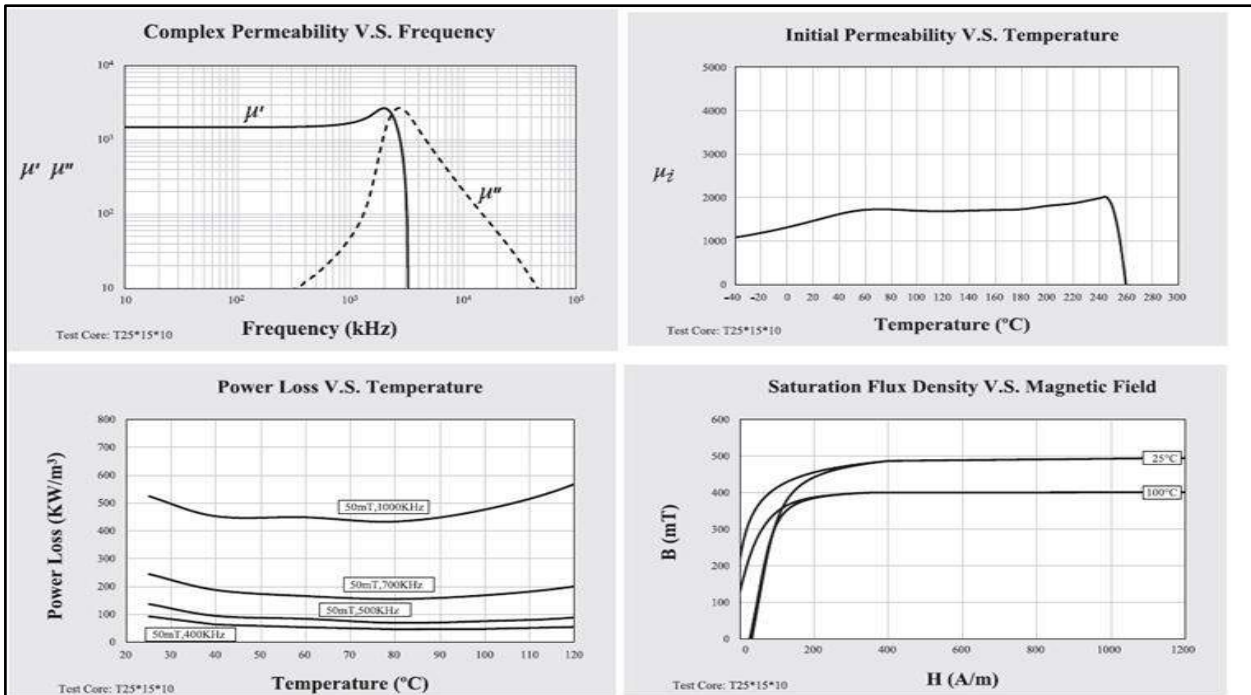



Material Properties	Symbol	Unit	Measuring Conditions			SFA05
			Freq.	Flux den.	Temp.	
Initial Permeability	μ_i	-	10kHz	0.25mT	25°C	5000±25%
Power Loss	Pv	kW/m ³	25kHz	200mT	25 °C	-
					100°C	-
			100kHz	200mT	25 °C	-
					100°C	-
			300kHz	100mT	25 °C	-
					100°C	-
500kHz	50mT	25 °C	-			
		100°C	-			
Saturation Flux Density	Bms	mT	10KHz	H=1200A/m	25°C	440
					100°C	300
Remanence	Brms	mT	10KHz	H=1200A/m	25°C	80
					100°C	90
Coercivity	Hc	A/m	10kHz	H=1200A/m	25°C	-
					100°C	-
Relative Loss Factor	tan δ / μ_i	10 ⁻⁶	10KHz	<0.25mT	25°C	<4
			100kHz		25°C	<15
Hysteresis Material Constant	η_B	10 ⁻⁶ /mT	10KHz	1.5-3.0mT	25°C	<0.8
Disaccommodation Factor	D _F	10 ⁻⁶	10KHz	< 0.25mT	25°C	<3
Curie Temperature	T _c	°C	-	-	-	≥140
Resistivity	ρ	Ω m	-	-	-	0.2
Density	d	g/cm ³	-	-	-	4.85

Note: Material characteristics are typical for a toroid core.
 Product specification will differ from these data due to the influence of geometry and size.

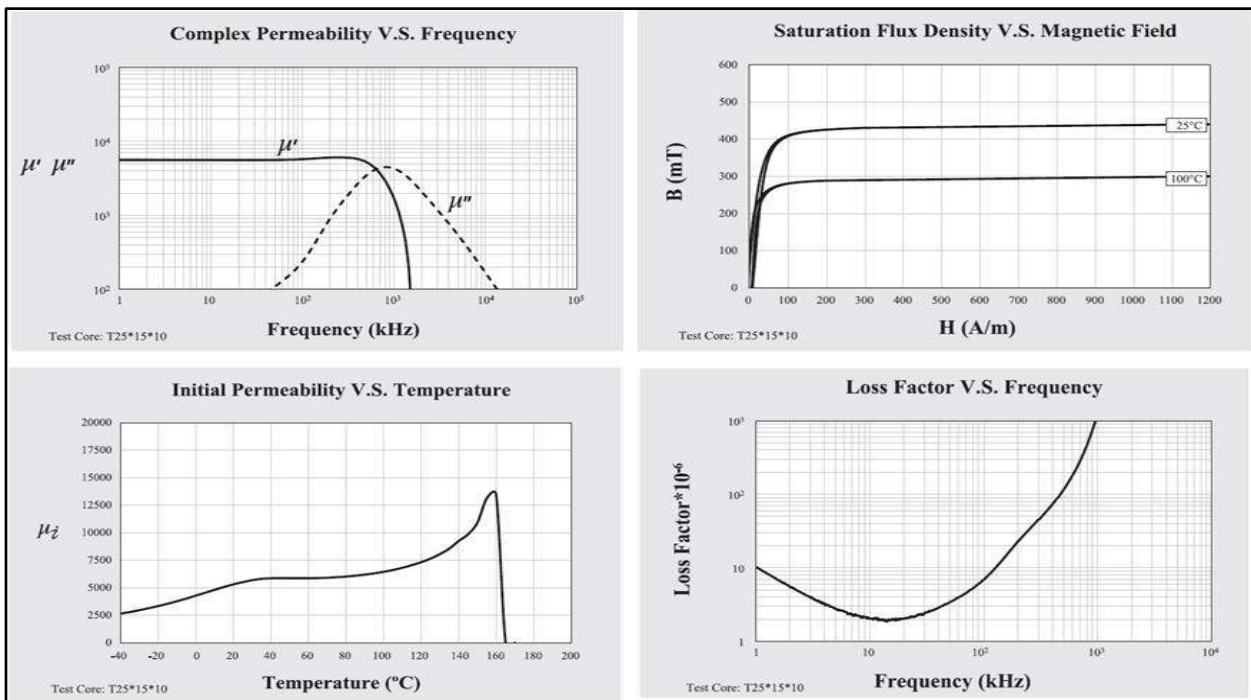



Material Properties	Symbol	Unit	Measuring Conditions			SFA07
			Freq.	Flux den.	Temp.	
Initial Permeability	μ_i	-	10kHz	0.25mT	25°C	7000±25%
Power Loss	Pv	kW/m ³	25kHz	200mT	25 °C	-
					100°C	-
			100kHz	200mT	25 °C	-
					100°C	-
			300kHz	100mT	25 °C	-
					100°C	-
500kHz	50mT	25 °C	-			
		100°C	-			
Saturation Flux Density	Bms	mT	10KHz	H=1200A/m	25°C	400
					100°C	200
Remanence	Brms	mT	10KHz	H=1200A/m	25°C	150
					100°C	110
Coercivity	Hc	A/m	10kHz	H=1200A/m	25°C	-
					100°C	-
Relative Loss Factor	tan δ / μ_i	10 ⁻⁶	10KHz	<0.25mT	25°C	<8
			100kHz		25°C	<30
Hysteresis Material Constant	η_B	10 ⁻⁶ /mT	10KHz	1.5-3.0mT	25°C	<1.2
Disaccommodation Factor	D _F	10 ⁻⁶	10KHz	< 0.25mT	25°C	<2
Curie Temperature	T _c	°C	-	-	-	≥130
Resistivity	ρ	Ω m	-	-	-	0.35
Density	d	g/cm ³	-	-	-	4.9

Note: Material characteristics are typical for a toroid core.
Product specification will differ from these data due to the influence of geometry and size.

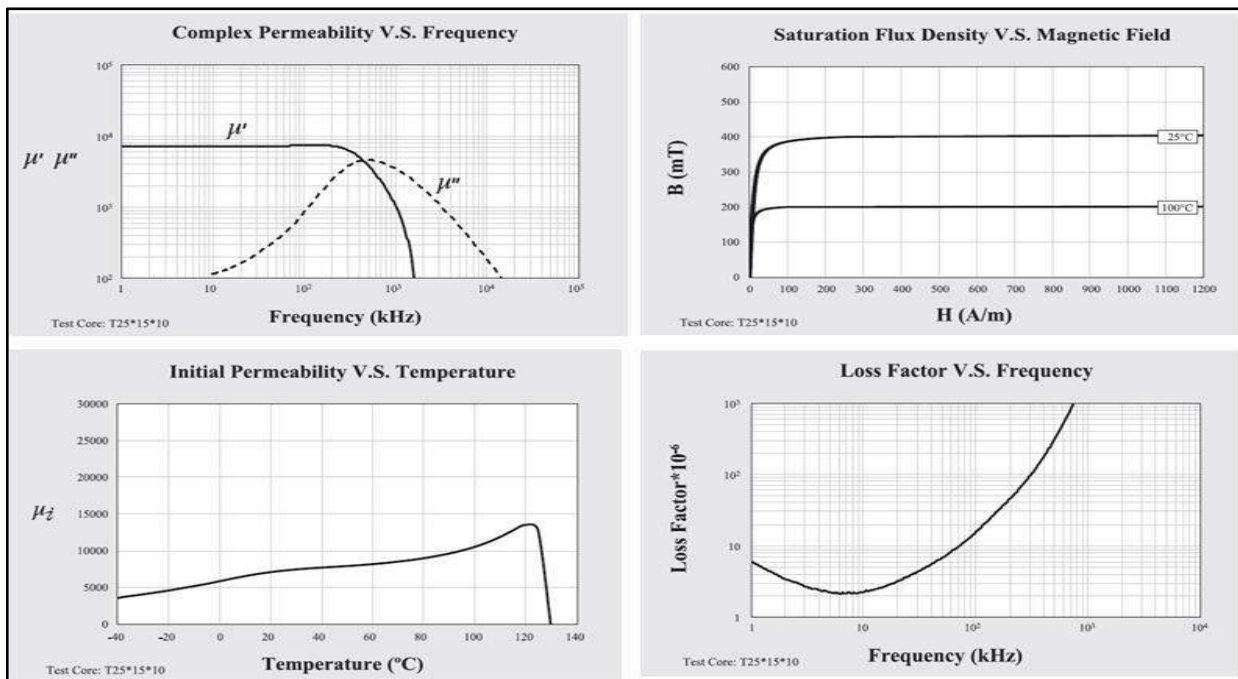



Material Properties	Symbol	Unit	Measuring Conditions			SFA10
			Freq.	Flux den.	Temp.	
Initial Permeability	μ_i	-	10kHz	0.25mT	25°C	10000±30%
Power Loss	Pv	kW/m ³	25kHz	200mT	25 °C	-
					100°C	-
			100kHz	200mT	25 °C	-
					100°C	-
			300kHz	100mT	25 °C	-
					100°C	-
500kHz	50mT	25 °C	-			
		100°C	-			
Saturation Flux Density	Bms	mT	10KHz	H=1200A/m	25°C	410
					100°C	210
Remanence	Brms	mT	10KHz	H=1200A/m	25°C	140
					100°C	110
Coercivity	Hc	A/m	10kHz	H=1200A/m	25°C	-
					100°C	-
Relative Loss Factor	tan δ / μ_i	10 ⁻⁶	10KHz	<0.25mT	25°C	<10
			100kHz		25°C	<60
Hysteresis Material Constant	η_B	10 ⁻⁶ mT	10KHz	1.5-3.0mT	25°C	<0.5
Disaccommodation Factor	D _F	10 ⁻⁶	10KHz	< 0.25mT	25°C	<2
Curie Temperature	T _C	°C	-	-	-	≥130
Resistivity	ρ	Ω m	-	-	-	0.15
Density	d	g/cm ³	-	-	-	4.9

Note: Material characteristics are typical for a toroid core.
 Product specification will differ from these data due to the influence of geometry and size.

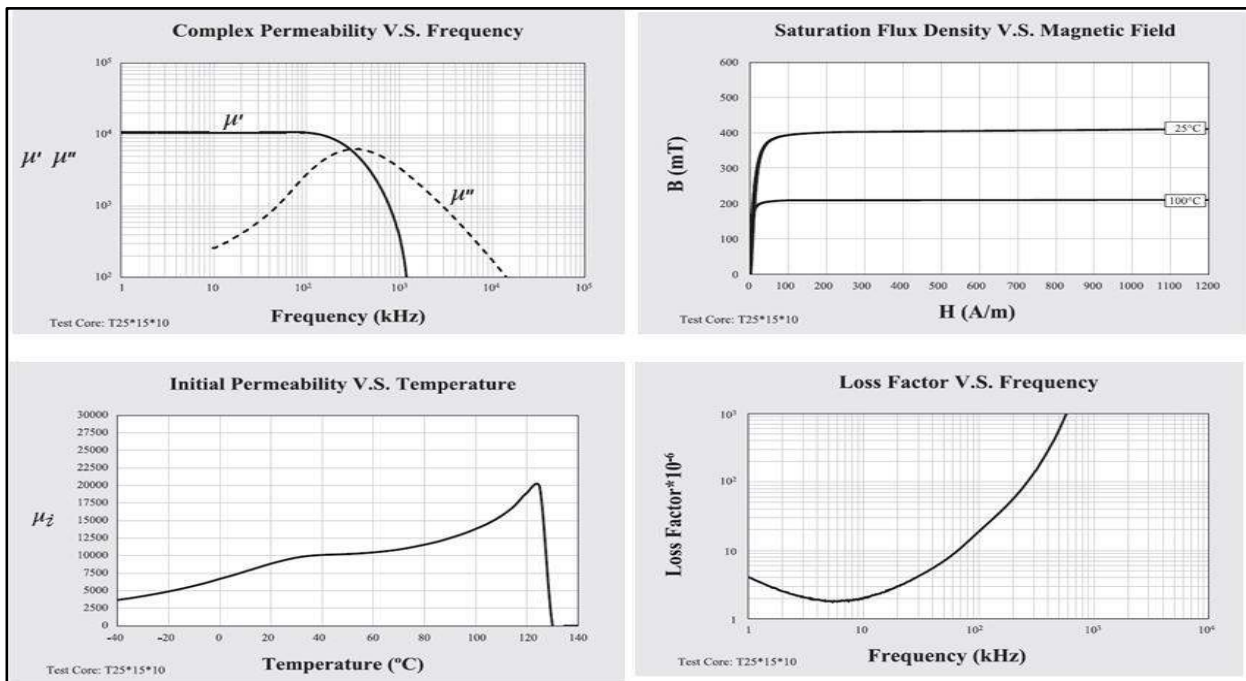



Material Properties	Symbol	Unit	Measuring Conditions			SFA12
			Freq.	Flux den.	Temp.	
Initial Permeability	μ_i	-	10kHz	0.25mT	25°C	12000±30%
Power Loss	Pv	kW/m ³	25kHz	200mT	25 °C	-
					100°C	-
			100kHz	200mT	25 °C	-
					100°C	-
			300kHz	100mT	25 °C	-
					100°C	-
500kHz	50mT	25 °C	-			
		100°C	-			
Saturation Flux Density	Bms	mT	10KHz	H=1200A/m	25°C	380
					100°C	180
Remanence	Brms	mT	10KHz	H=1200A/m	25°C	130
					100°C	110
Coercivity	Hc	A/m	10kHz	H=1200A/m	25°C	-
					100°C	-
Relative Loss Factor	tan δ / μ_i	10 ⁻⁶	10KHz	<0.25mT	25°C	<10
			100kHz		25°C	<60
Hysteresis Material Constant	ηB	10 ⁻⁶ /mT	10KHz	1.5-3.0mT	25°C	<0.5
Disaccommodation Factor	D _F	10 ⁻⁶	10KHz	< 0.25mT	25°C	<2
Curie Temperature	T _c	°C	-	-	-	≥110
Resistivity	ρ	Ωm	-	-	-	0.12
Density	d	g/cm ³	-	-	-	4.9

Note: Material characteristics are typical for a toroid core.
 Product specification will differ from these data due to the influence of geometry and size.

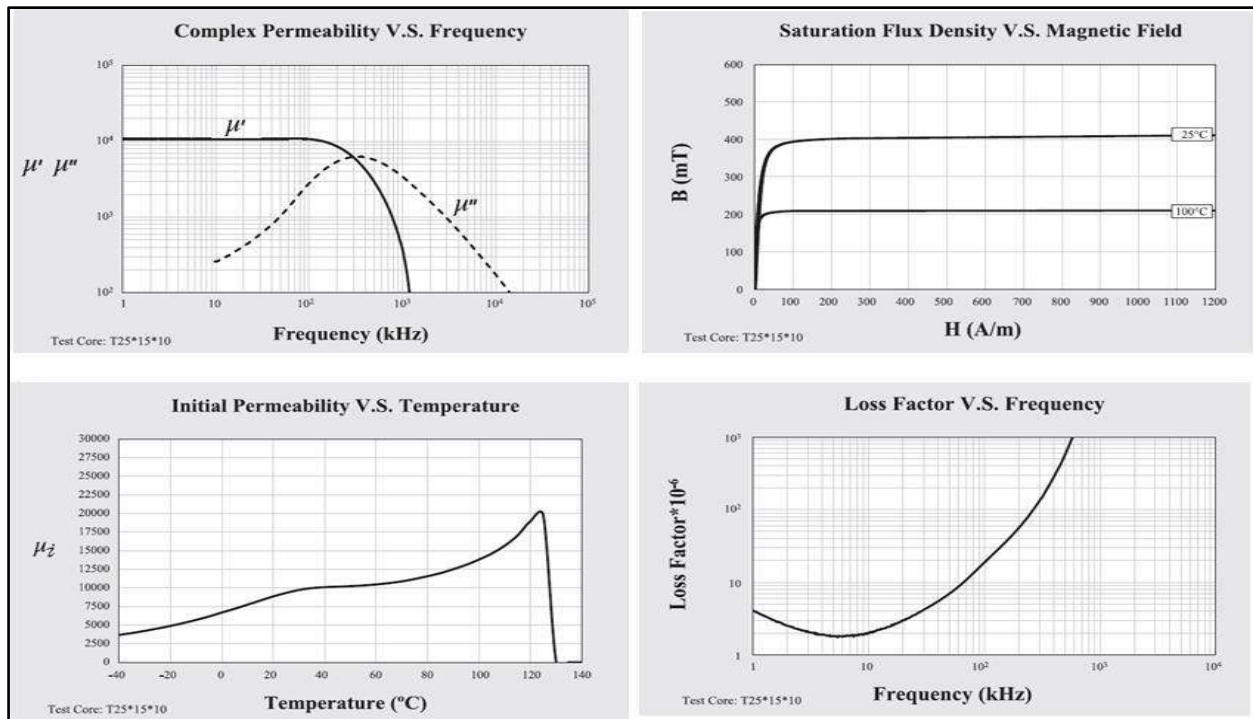

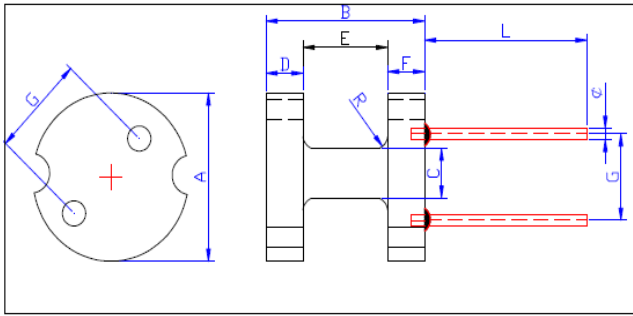

Geometry	Dimensions								Material Grade
Type	A (mm)	B (mm)	C (mm)	D (mm)	E (mm)	F (mm)	G (mm)	L (mm)	AL Value in nH
									SFP40T
DR6*8 with pin with cut	6.0±0.25	8.3±0.3	2.5±0.20	2.0±0.15	4.3±0.2	2.0±0.15	3.0±0.5	10.5±0.5	26.3±15%
DR8*10 with pin with cut	8.0±0.20	10±0.3	3.5±0.15	2.0±0.15	5.8±0.2	2.0±0.15	5.0±0.5	10.5±0.5	26.3±15%
DR8*12 with pin with cut	8.0±0.25	12.0±0.3	3.5±0.2	2.0±0.20	7.0±0.25	2.5±0.20	5.0±0.3	10.5±0.5	38.8±15%
DR10*12 with pin with cut	10.0±0.25	12±0.3	5.0±0.25	2.5±0.15	4.0±0.4	2.5±0.15	5.0±0.3	10.5±0.5	38.8±15%
DR12*15 with pin with cut	12.0±0.30	15.0±0.3	5.0±0.25	2.5±0.15	10.0±0.25	2.5±0.15	7.0±0.3	10.5±0.5	47.6±15%

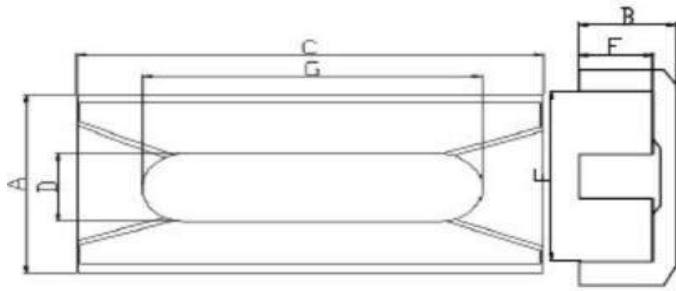

Geometry	Dimensions				
Type	A (mm)	B (mm)	C (mm)	D (mm)	E (mm)
EDR2009	13.5±0.5	4.6±0.2	20.2±0.5	2.70±0.2	10.4 min
EDR2609	13.5±0.5	4.6±0.2	26.0±0.5	2.70±0.2	10.4 min
EDR2809	13.5±0.5	5.0±0.2	28.0±0.5	3.2±0.2	10.0 min
EDR3909	13.5±0.5	4.5±0.2	39.4±0.2	2.70±0.2	10.4 min

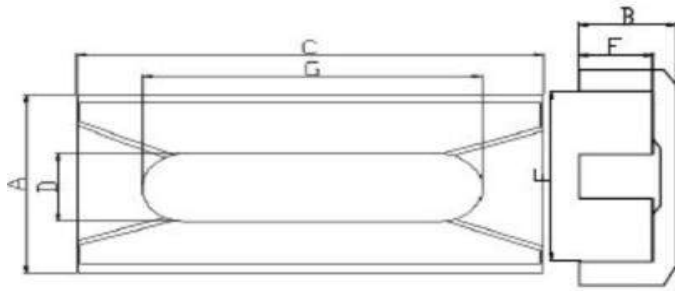

Dimensions		Electrical Characteristics			Material Grade
F (mm)	G (mm)	Le	Ae	Ve	AL Values in nH
		mm	mm ²	mm ³	SFP95
2.90±0.20	15.75±0.30	20.6	56.3	1159.0	4000±25%
2.70±0.20	21.75±0.30	23.6	71.0	1677.8	6500 ±25%
3.40±0.20	25.3±0.30	26.7	77.1	2060.0	6500 ±25%
2.80±0.20	35.0±0.20	24.8	102.3	2537.5	7500 ±25%

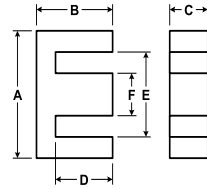

Geometry	Dimensions					
Type	A (mm)	B (mm)	C (mm)	D (mm)	E (mm)	F (mm)
EE8.3/4/4	8.60±0.20	4.4±0.20	3.80±0.20	3.3±0.20	5.90 min	2.00±0.20
EE10/5.5/5	10.20±0.20	5.8±0.20	4.80+0.0/-0.3	4.55±0.20	7.70 min	2.40±0.20
EE10.8/5.8/5	10.80±0.20	5.8±0.20	4.80±0.20	4.55±0.20	7.80 min	2.50±0.20
EE11/5.8/05	11.20±0.20	5.8±0.20	5.00±0.20	4.55±0.20	7.90min	2.50±0.20
EE12.6/6.5/6.3	12.65+/-0.30	6.55±0.30	6.15+/-0.15	4.9±0.30	8.90 min	3.70+0.0/-0.3
EE13/06/06	13.20±0.30	6.5±0.30	6.00±0.20	4.9±0.30	9.70 min	2.75±0.20
EE14.2/5/7.2	14.20±0.30	5±0.30	7.20±0.20	3.1±0.30	10.20 min	3.45±0.20
EE14.2/4.7/7.2	14.20±0.30	4.65±0.30	7.20±0.20	3±0.30	10.20 min	3.45±0.20
EE14.5/06/10	14.50±0.30	6.6±0.30	9.80±0.20	4.95±0.30	10.50 min	3.50±0.20
EE16/06/05	16.10+/-0.30	6.1±0.30	4.7+0.0/-0.3	4.1±0.30	11.30 min	4.55±0.20
EE16/06/07	16.10+/-0.30	6.2±0.30	7.10±0.20	4.2±0.30	11.30 min	4.55±0.20
EE16/07/05	16.20±0.30	7.45±0.30	4.80±0.20	5.45±0.30	11.70 min	4.00±0.30
EE16/08/05	16.10+/-0.30	8.2±0.30	4.70+0.0/-0.4	6.1±0.30	11.30 min	4.70+0.0/-0.3
EE16/08/10	16.10±0.30	7.7±0.30	10.0±0.20	5.7±0.30	11.30 min	4.40±0.30
EE17/08/10	17.10±0.30	7.7±0.30	9.80±0.20	5.7±0.30	12.15 min	3.90±0.20
EE16/08/07	16.10+/-0.30	8.25±0.30	7.00±0.20	6.25±0.30	11.20 min	4.60±0.20
EE17/06/08	17.20±0.30	6.35±0.30	8.00±0.20	4±0.30	12.60 min	4.0±0.30
EE19/08/05	19.20±0.30	8.2±0.30	4.80±0.20	6.1±0.30	14.00 min	4.70±0.20
EE19/08/07	19.20±0.30	8.25±0.30	6.70±0.20	6.1±0.30	14.30 min	4.70±0.20
EE19/08/10	19.20±0.30	8.1±0.30	9.70±0.20	5.8±0.30	14.00 min	4.40±0.20
EE20/10/06	20.20±0.30	10.4±0.30	5.70±0.25	7.4±0.30	14.10 min	5.60±0.20
EE20/10/09	20.20±0.30	10.4±0.30	9.00±0.25	7.4±0.30	14.10 min	5.70±0.20
EE21/10/09	21.20±0.30	10.4±0.30	8.90±0.25	7.4±0.30	15.10 min	5.70±0.20
EE20/10/11	20.10+/-0.30	10.1±0.30	10.60±0.30	7.2±0.30	14.50 min	5.70±0.20
EE21/10/11	21.10+/-0.30	10.1±0.30	10.60±0.25	7.2±0.30	15.30 min	5.70±0.20
EE22/08/13	22.3+/- 0.3	8.3±0.30	12.90±0.25	5.4±0.30	15.50 min	5.60±0.20
EE25/09/06	25.40±0.30	9.75±0.30	6.25±0.25	6.95±0.30	18.60 min	6.30±0.30
EE25/13/07	25.10+/-0.30	12.6±0.30	7.20±0.25	9.1±0.30	17.50 min	7.20±0.30
EE25/13/11	25.10+/-0.30	12.6±0.30	10.90±0.25	9.1±0.30	17.50 min	7.20±0.30
EE28/10/11	28.10±0.30	10.6±0.30	10.70±0.25	6.8±0.30	20.40 min	7.20±0.30
EE30/15/07	30.10±0.40	15.1±0.30	7.05±0.25	10.1±0.30	19.50 min	6.95±0.25
EE32/16/09	32.10±0.40	16.1±0.30	9.15±0.25	11.6±0.30	22.70 min	9.20±0.25
EE42/21/15	42.20+/-0.40	21.1±0.40	14.95±0.30	15.15±0.40	29.50 min	12.10±0.20
EE42/21/20	42.20+/-0.40	21.1±0.40	20.00+0/-0.6	15.15±0.40	29.50 min	12.20+0/-0.5
EE55/28/21	55.20+/-0.40	27.5±0.40	20.70±0.30	18.9±0.40	37.50 min	16.95±0.25
EE55/28/25	55.20+/-0.40	27.5±0.40	24.80±0.30	18.9±0.40	37.50 min	16.95±0.25
EE65/32/27	65.20+/-0.50	32.5±0.40	27.20+/-0.4	22.6±0.40	44.20 min	19.70+/-0.50
EE65/32/13	65.20+/-0.50	32.5±0.40	13.70-0.60	22.6±0.40	44.20 min	20.00+/-0.50
EE100/60/28	100.3+/-1.00	59.4±0.50	27.5+/-0.5	45.85±0.50	72.00 min	27.50+/-0.50

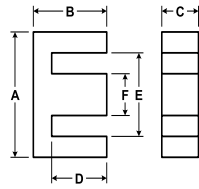

Electrical Characteristics			Material Grades		SFP4, P _V (100kHz, 200mT, 100°C) (W/Set)	SFP95, P _V (100kHz, 200mT, 100°C) (W/Set)
Le	Ae	Ve	AL Values in nH			
mm	mm ²	mm ³	SFP4	SFP95		
19.5	7.6	136.6	600±25%	750±25%	≤0.094	≤0.092
27.1	11.52	302.7	800±25%	920±25%	≤0.15	≤0.08
27.0	12.1	326.7	800±25%	920±25%	≤0.15	≤0.08
27.7	12.5	366.7	950±25%	1200±25%	≤0.24	≤0.22
29.6	22.4	663.0	1380+30%-20%	-	≤0.29	-
30.2	16.5	520.0	1100±25%	1200±25%	≤0.38	≤0.235
25.0	25.1	647.9	1700±25%	2800±25%	≤0.47	≤0.40
25.2	24.9	641.2	1700±25%	2800±25%	≤0.47	≤0.40
32.0	34.2	1094.1	2100±25%	-	≤0.76	-
28.6	21.4	549.0	1200±25%	1250±25%	≤0.30	0.24
28.9	32.7	945.2	1800+30%-20%	2400±25%	≤0.49	≤0.40
35.1	19.2	675.0	1000+30%-20%	1400±25%	≤0.40	≤0.35
37.6	22.1	756.0	1100±25%	1350±25%	≤0.38	≤0.32
37.5	44	1546.9	1720±25%	3200±25%	≤1.00	≤0.95
37.7	37.7	1491.8	2400±25%	3200±25%	≤1.00	≤0.95
40.5	32.2	1292.8	1900+30%-20%	-	≤0.93	-
31.7	32.0	1068.3	1900nH±25%	2800±25%	≤0.65	-
39.6	22.5	891.0	1150+30%-20%	-	≤0.50	≤0.45
40.6	31.0	1254.3	1600±25%	-	≤0.75	-
40.5	42.7	1811.6	2400+30%-20%	-	≤1.00	≤0.90
46.3	32.1	1490.0	1570+30%-20%	2000±25%	≤0.75	-
46.2	51.1	2357.0	2200±25%	-	≤1.40	-
47.5	51.73	2257.9	2200±25%	-	≤1.40	-
46.5	60.42	2640.3	2730±25%	3000+30/-20%	≤1.40	≤1.38
46.0	62.5	2787.0	2730±25%	3000+30/-20%	≤1.40	≤1.38
40.6	72.2	3191.4	2800±25%	-	≤1.40	-
49.2	38.8	1910.0	1670+30%-20%	-	≤1.20	-
57.5	52.5	3020.0	1850+30%-20%	2300±25%	≤1.60	≤1.45
57.8	78.5	4440.0	2700+30%-20%	-	≤2.15	-
51.6	80.2	4215.0	3500±25%	-	≤2.40	-
66.1	50.1	5900.3	1900+30%-20%	-	≤2.20	-
74.0	83.1	6140.0	2300+30%-20%	-	≤3.00	-
97.0	178.0	17300.0	3950+30%-20%	5100+30/-20%	≤9.00	≤8.70
97.0	234.0	22700.0	5200+30%-20%	6700+30/-20%	≤2.40 @ 100mT	≤2.2 @ 100mT
124.0	354.0	43900.0	6400+30%-20%	8300±25%	≤3.80 @ 100mT	≤3.60 @ 100mT
124.0	420.0	52100.0	7300+30%-20%	8300+30%-20%	≤4.80 @ 100mT	-
147.0	535.0	78600.0	7900+30%-20%	8500+30%-20%	≤6.70 @ 100mT	≤6.50 @ 100mT
147.0	267.0	39200.0	3950+25%-25%	-	-	-
274.0	735.0	201390.0	6500+30%-20%	-	≤4.70 @ 100mT/25kHz	≤4.80 @ 100mT/25kHz

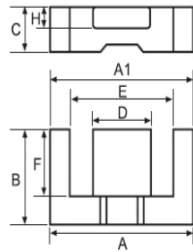

Geometry	Dimensions						
Type	A (mm)	B (mm)	C (mm)	D (mm)	E (mm)	F (mm)	H (mm)
EFD15.8/8/5	15.80±0.30	7.8±0.30	4.60±0.20	5.25±0.30	11.60±0.35	5.75±0.30	2.30±0.15
EFD20/10/7	20.5±0.30	10.6±0.30	6.65±0.15	8.90±0.20	15.60 min	8.1±0.30	3.60±0.15
EFD21/10/7	21.3±0.30	10.6±0.30	6.65±0.15	8.90±0.20	16.10 min	8.1±0.30	3.60±0.15
EFD25/13/9	25.20±0.30	12.7±0.30	9.10±0.20	11.30±0.20	18.50 Min	9.6±0.30	5.20±0.15
EFD25.8/13/9	25.80±0.30	12.7±0.30	9.10±0.20	11.30±0.20	19.50 min	9.6±0.30	5.10±0.15
EFD31/15/09	31.60±0.30	15.2±0.30	9.25±0.25	14.50±0.25	23.60 min	11.3±0.30	4.75±0.20

EI Cores

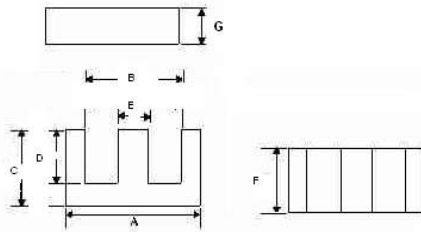

Geometry	Dimensions				
Type	A (mm)	B (mm)	C (mm)	D (mm)	E (mm)
EI28/11	28.00±0.4	18.6+0.8	17.3±0.3	12.8±0.2	7.5-0.8
EI30/11	30.0+0.7/-0.20	20.7+0.7	21.0+0.6	16.0+0.6	11.0-0.7
EI33/13	33.0±0.50	23.2+0.8	23.30±0.3	19.05±0.35	9.7±0.3
EI35/12	35.0+0.8/-0.5	25.0+0.8	23.80±0.7	18.0+0.6	10.3-0.6
EI40/12	40.0±0.50	27.2+1.0	27.20±0.5	20.0±0.5	12.0-0.7

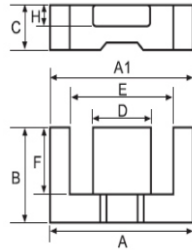

Electrical Characteristics			Material Grades		SFP4, P _v (100kHz, 200mT,100°C) (W/Set)	SFP95, P _v (100kHz, 200mT,100°C) (W/Set)
Le	Ae	Ve	AL Values in nH			
mm	mm ²	mm ³	SFP4	SFP95		
36.1	14.86	536.5	780+30%-20%	1050+/-25%	≤0.28	
47	31	1460	1200+30/-20%	1800+/-25%	≤1.05	≤0.86
48.73	30.65	1482.8	1200+30/-20%	1800+/-25%	≤1.05	≤0.86
59.18	53.28	3153	2000+30%-20%	2800+/-25%	≤1.80	
60.73	54.65	3325.8	2000+30%-20%	2800+/-25%	≤1.80	
68	69	4690	2050±25%	-	≤2.60	

EI Cores

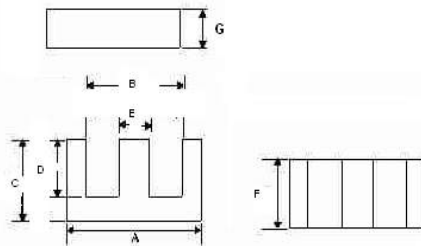

Dimensions		Electrical Characteristics			Material Grades
F (mm)	G (mm)	Le	Ae	Ve	AL Values in nH
		mm	mm ²	mm ³	SFP4
11.0-0.6	3.5±0.2	49.5	84.4	4177.8	3600+30/-20%
11.0-0.7	5.5±0.2	58.5	110.4	6458.4	3700+30/-20%
12.70±0.3	5.0±0.2	66.9	118.8	7948	3600+30/-20%
11.70±0.6	5.5±0.2	67.3	120	8076	3600+30/-20%
12.0-0.7	7.5±0.3	76.8	148	11366.4	3950+30/-20%

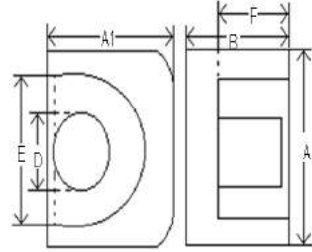

Geometry	Dimensions					
Type	A (mm)	A1 (mm)	B (mm)	D (mm)	E (mm)	F (mm)
EP5/3/4	6.00±0.15	3.80±0.10	2.80±0.05	1.70±0.10	4.40±0.15	2.00±0.10
EP7/3.5/6	9.20±0.20	6.35±0.15	3.75±0.10	3.30±0.10	7.40±0.20	2.60±0.10
EP10/5/7	11.50±0.30	7.65±0.20	5.20±0.10	3.30±0.15	9.40±0.20	3.70±0.10
EP13/6.5/9	12.50±0.30	8.80±0.20	6.50±0.10	4.35±0.15	10.10±0.20	4.60±0.10
EP13/6.5/9 Laker	12.60±0.30	8.80±0.20	6.62±0.15	4.35±0.15	10.10±0.30	4.80±0.15
EP17/8.5/11	18.00±0.40	11.00±0.20	8.40±0.20	5.70±0.20	12.00±0.40	5.65±0.15

EPC Cores

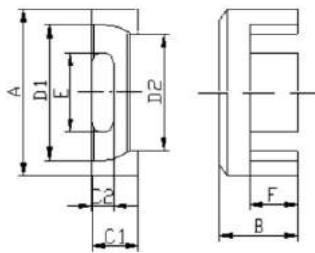

Geometry	Dimensions							
Type	A (mm)	B (mm)	C1 (mm)	C2 (mm)	D1 (mm)	D2 (mm)	E (mm)	F (mm)
EPC13/6.5/4.7	13.60±0.30	6.7±0.20	4.70±0.15	2.00±0.10	10.30 min	8.10 min	5.30 Min	4.8±0.20
EPC14/6.5/4.7	14.30±0.30	6.7±0.20	4.70±0.15	2.00±0.10	11.40 min	9.40 min	5.40±0.10	4.8±0.20
EPC17/8.50/6	17.80±0.40	8.55±0.20	6.00±0.20	2.60±0.20	14.60 min	11.80 min	7.50±0.20	6.1±0.20

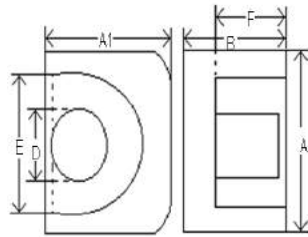

Electrical Characteristics			Material Grades	
Le	Ae	Ve	AL Values in nH	
mm	mm ²	mm ³	SFP4	SFA05
9.7	3.0	28.7	400±25%	-
15.7	10.3	162.0	1100+30/-20%	2000+30/-20%
19.2	11.3	217.0	1000+30/-20%	2000+30/-20%
24.2	19.5	472.0	1600+30/-20%	2800+30/-20%
24.2	19.5	472.0	1600+30/-20%	2800+30/-20%
28.7	34.0	970.0	2500+30/-20%	-

EPC Cores

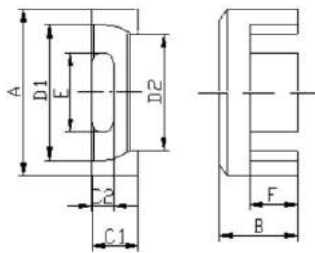

Electrical Characteristics			Material Grade	SFP4, P _v (100kHz, 200mT, 100°C) (W/Set)
Le	Ae	Ve	AL Values in nH	
mm	mm ²	mm ³	SFP4	
29.4	13.7	402.1	850±25%	≤0.25
30.8	13.0	386.0	850±25%	≤0.30
40.8	20.0	817.0	1150±25%	≤0.25

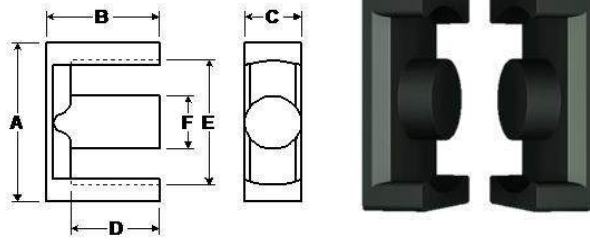

Geometry	Dimensions					
Type	A (mm)	B (mm)	C (mm)	D (mm)	E (mm)	F (mm)
ER28/14/11	28.55±0.55	14.2±0.40	11.40±0.25	9.9±0.40	21.80 min	9.90±0.25
ER29/17/11	29.50±0.60	17±0.40	11.40±0.25	12.7±0.40	22.40 min	9.90±0.25
ER35/20/11	35.0±0.6	20.7±0.4	11.3±0.25	14.7±0.40	25.6min	11.3±0.25
ER35/22/11	35.0±0.6	21.4±0.4	11.3±0.25	15.4±0.40	25.6min	11.3±0.25
ER42/22/15	42.0+1.0/-0.7	21.6±0.4	14.7±0.30	15.95±0.40	30.4min	14.7±0.3

EQ Cores

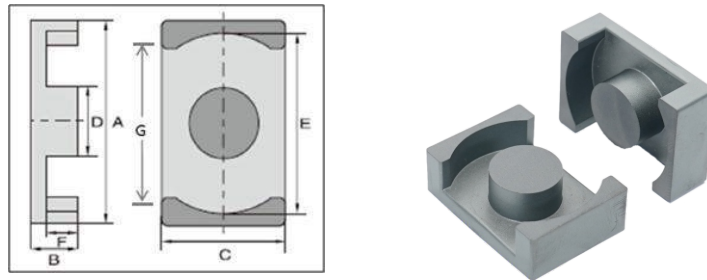

Geometry	Dimensions						
Type	A (mm)	B (mm)	C (mm)	D (mm)	E (mm)	F (mm)	G (mm)
EQ25/14	25.10±0.30	7.3±0.20	18.00±0.30	10.80±0.20	21.50 Min	5.1±0.20	16.00 min
EQ25/15	25.10±0.30	7.5±0.20	18.00±0.30	10.80±0.20	21.50 Min	5.4±0.20	16.00 min
EQ30/16	30.0 ±0.40	8±0.15	20.0 ±0.30	11.0 ±0.20	25.60 min	5.3±0.20	19.0 min
EQ31/17	31.5 ±0.50	8.5±0.20	20.30 ±0.40	13.20 ±0.25	26.30 min	5.35±0.20	21.8 min

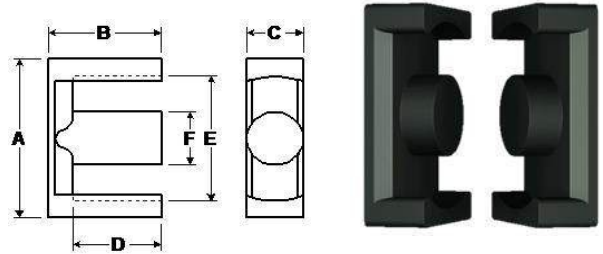

Electrical Characteristics			Material Grade	
Le	Ae	Ve	AL Values in nH	SFP4, P _v (100kHz, 200mT, 100°C) (W/Set)
mm	mm ²	mm ³	SFP4	
63.4	86.0	5460	2700±25%	
77.27	84.0	6478	2450±25%	≤1.90
89.6	111.0	9930	2700±25%	≤2.50
90.8	111.0	10800	2650±25%	≤2.50
99.0	170.0	16800	3700±25%	≤3.80

EQ Cores

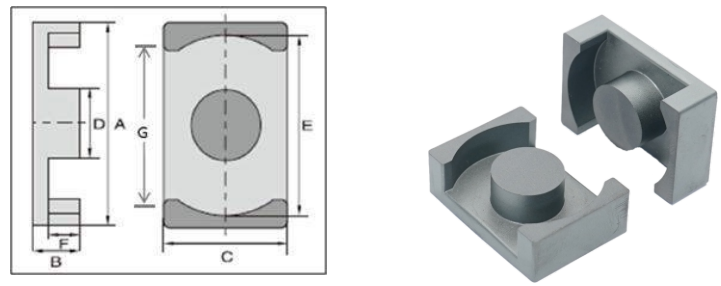

Electrical Characteristics			Material Grade	
Le	Ae	Ve	AL Values in nH	SFP4, P _v (100kHz, 200mT, 100°C) (W/Set)
mm	mm ²	mm ³	SFP4	
38.2	89.0	3461.2	4800±25%	
38.2	89.0	3461.2	4500±25%	≤1.98
46.00	108.0	4970	4900 ±25%	≤ 2.70
43.8	136.2	5961.5	6200 ±25%	≤ 4.25

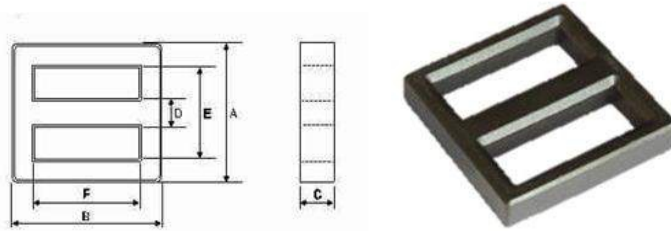

Geometry	Dimensions					
Type	A (mm)	B (mm)	C (mm)	D (mm)	E (mm)	F (mm)
ET20/20/04	20.10±0.40	20.10±0.40	4.40±0.20	4.00±0.20	15.70min	15.70min
ET24/24/08	24.20±0.50	24.20±0.50	4.00±0.30	4.00±0.20	19.00min	19.00min
ET28/28/05	28.40±0.50	28.40±0.50	5.00±0.30	5.00±0.30	22.20min	22.20min
ET29/29/05	28.70±0.50	28.70±0.50	5.00±0.30	5.00±0.30	22.20min	22.20min
ET35/35/07	35.30±0.60	35.30±0.60	7.40±0.25	7.40±0.25	26.80min	26.80min

ETD Cores

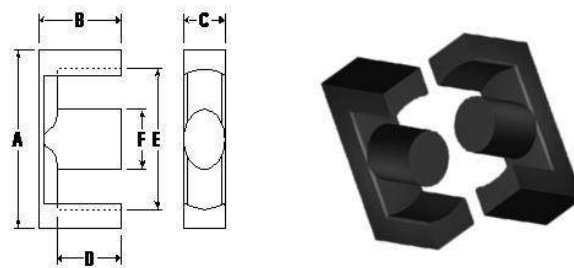

Geometry	Dimensions					
Type	A (mm)	B (mm)	C (mm)	D (mm)	E (mm)	F (mm)
ETD29/16/10	29.80±0.40	16±0.40	9.50±0.30	11.3±0.40	22.00 min	9.50±0.30
ETD34/17/11	34.50±0.40	17.5±0.40	10.80±0.30	12.6±0.40	25.60 min	10.80±0.30
ETD39/20/13	39.00±0.40	20±0.40	12.50±0.30	14.5±0.40	29.30 min	12.50±0.30
ETD39/21/13	39.00±0.40	21.1±0.40	12.50±0.30	15.9±0.40	29.30 min	12.50±0.30
ETD44/22/15	44.00±0.40	22.4±0.40	14.80±0.40	16.6±0.40	32.50 min	14.80±0.40
ETD49/25/16	48.70±0.40	24.8±0.40	16.30±0.40	18.2±0.40	36.10 min	16.70+0/-0.8

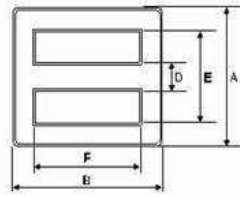

Electrical Characteristics			Material Grades		
Le	Ae	Ve	AL Values in nH		
mm	mm ²	mm ³	SFA07	SFA10	SFA12
52.1	17.6	917.0	3100±25%	4400±25%	4850±25%
60.0	18.0	1098.0	2800±25%	≥3500	4300±25%
70.0	27.0	1972.0	3500±25%	4500±25%	5800±25%
71.4	28.02	2000.7	3600±25%	-	-
86.9	57.1	4962.0	5750+30%/-20%	-	-

ETD Cores

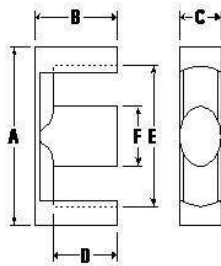

Electrical Characteristics			Material Grades		SFP4, P _v (100kHz, 200mT, 100°C) (W/Set)
Le	Ae	Ve	AL Values in nH		
mm	mm ²	mm ³	SFP4	SFP95	
70.4	76.0	5350.0	2200+30/-20%	3000+/-25%	≤2.80
78.6	97.1	7630.0	2600+/-25%	3300+30/-20%	≤4.00
92.3	125.0	11500.0	2700+30%/-20%	-	≤6.00
97.1	128.7	12499.2	2650+/-25%	-	≤6.00
103.0	173.0	17800.0	3500+/-25%	4400+30/-20%	≤9.40
114.6	212.3	24317.7	3800+30/-20%	-	≤12.40

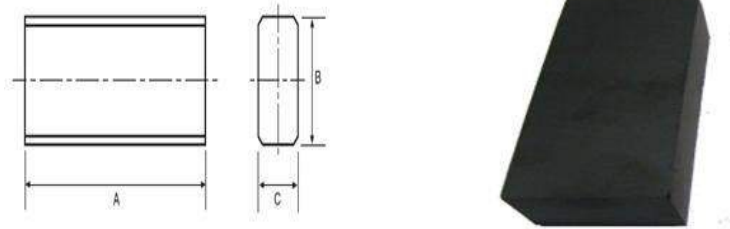

Geometry	Dimensions			Material
Type	A [mm]	B [mm]	C [mm]	Grade
I48/48/2.7	48.0±0.50	48.0±0.50	2.70±0.20	SFP95
I53.3/53.3/2.7	53.30±0.80	53.30±0.80	2.70±0.20	SFP95
I60/15/06	60.0±1.0	15.0±0.80	6.0±0.50	SFP95
I70/15/06	70.0±1.0	15.0±0.80	6.0±0.50	SFP95
I100/40/06	100.0±2.0	40.0±1.0	6.0±0.50	SFP95
I100/52.5/06 (Special)	100.0±2.0	52.50±1.0	6.0±0.50	SFP95
I100/100/06	100.0±2.0	100.0±2.0	6.0±0.50	SFP95

Pot Cores

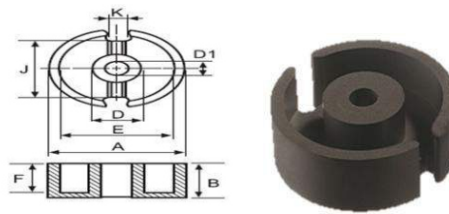

Geometry	Dimensions					
Type	A (mm)	B (mm)	D (mm)	E (mm)	F (mm)	J (mm)
POT9x5	9.15±0.15	2.65±0.05	3.80±0.10	7.62±0.15	1.87±0.10	5.65±0.15
POT11x7	11.10±0.20	3.30±0.10	4.60±0.10	9.20±0.20	2.3±0.10	6.80±0.25
POT14x8	14.00±0.25	4.20±0.10	5.99max	11.60min	2.79min	9.50±0.60
POT18x11CH	17.90±0.30	5.3±0.10	7.40±0.15	15.25±0.25	3.80±0.10	11.55±0.30
POT24.3x17.6CH	24.30±0.50	8.90±0/-0.45	10.88±0.30	20.83±0.5	5.90+04/-0.00	16.80±0.35
POT35.5x22CH	35.50±0.50	10.90±0.20	15.95±0.25	30.30±0.40	7.50±0.20	26.80±0.50
POT69x28CH	69.00±1.20	14.00±0.20	29.00±0.50	58.4+1.00/- 0.80	9.30±0.30	48.20±0.80

Pot Cores

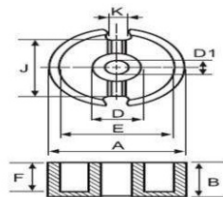

Dimensions		Electrical Characteristics			Material Grades		
K (mm)	D1 (mm)	Le	Ae	Ve	AL Values ($\pm 25\%$) in nH		
		mm	mm ²	mm ³	SFP4	SFP33	SFP48
2.10 \pm 0.30	-	13.52	12.76	172.52	1300	-	-
2.20 \pm 0.30	-	16.3	19	309	2000	800	2000
3.30 \pm 0.60	-	21	29.9	628	2500	1010	2400
3.20 \pm 0.30	3.00 \pm 0.1	25.8	43.3	1120	2850	-	2850
3.95 \pm 0.25	5.51 \pm 0.20	52.73	103.34	5448.97	4200	-	-
4.00 \pm 0.30	5.65 \pm 0.15	70.47	237.15	16712	7500	-	7500
10.50 \pm 0.50	8.50 \pm 0.50	78.49	624.89	49045.32	15000	-	-

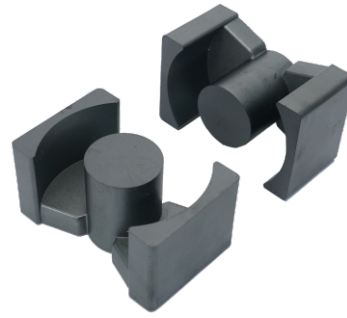
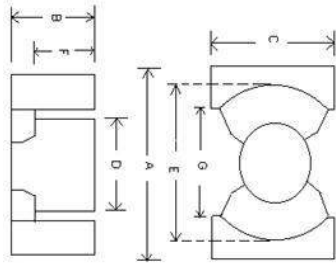

Geometry	Dimensions						
Type	A (mm)	B (mm)	C (mm)	D (mm)	E (mm)	F (mm)	G (mm)
PQ21/14	21.30±0.30	7±0.30	14.00±0.30	8.80±0.20	18.00 Min	4.5±0.30	13.00 min
PQ21/16	21.30±0.30	8.1±0.30	14.00±0.30	8.80±0.20	18.00 Min	5.15±0.30	13.00 min
PQ20/16	20.50±0.30	8.1±0.30	14.00±0.30	8.80±0.20	17.50 Min	5.15±0.30	12.00 min
PQ20/12	20.50±0.30	6.25±0.30	14.00±0.30	8.80±0.20	17.50 Min	3.75±0.30	12.00 min
PQ21/12	21.30±0.30	6.25±0.30	14.00±0.30	8.80±0.20	18.00 Min	3.75±0.30	13.00 min
PQ20/12.5	20.50±0.30	6.5±0.30	14.00±0.30	8.80±0.20	17.50 Min	4±0.30	12.00 min
PQ20/20	20.50±0.30	10.3±0.30	14.00±0.30	8.80±0.20	17.50 Min	7.3±0.30	12.00 min
PQ21/20	21.30±0.30	10.3±0.30	14.00±0.30	8.80±0.20	18.50 Min	7.3±0.30	13.00 min
PQ26/25	26.50±0.40	12.6±0.30	19.00±0.30	12.00±0.25	22.00 min	8.45±0.30	15.80 min
PQ26/20	26.50±0.40	10.4±0.30	19.00±0.30	12.00±0.25	22.00 min	6.5±0.30	15.80 min
PQ27/16	27.0±0.40	8.1±0.30	19.00±0.30	12.00±0.25	22.20 min	5±0.30	16.50 min
PQ27/20	27.0±0.40	10.4±0.30	19.00±0.30	12.00±0.25	22.20 min	6.5±0.30	16.50 min
PQ27.5/20	27.50±0.40	10.4±0.30	19.00±0.30	12.00±0.25	23.00 min	6.5±0.30	16.80 min
PQ27/25	27.00±0.40	12.6±0.30	19.00±0.30	12.00±0.30	22.20 min	8.45±0.30	16.50 min
PQ27.5/25	27.50±0.40	12.6±0.30	19.00±0.30	12.00±0.30	23.00 min	8.45±0.30	16.80 min
PQ32/20	32.00±0.40	10.45±0.30	22.00±0.40	13.45±0.30	27.00 min	6.3±0.30	19.00 min
PQ32/25	32.00±0.40	12.8±0.30	22.00±0.40	13.45±0.30	27.00 min	8.7±0.30	19.00 min
PQ32/30	32.00±0.40	15.4±0.30	22.00±0.40	13.45±0.30	27.00 min	11±0.30	19.00 min
PQ32.7/30	32.70±0.40	15.4±0.30	22.00±0.40	13.45±0.30	28.0 min	11±0.30	19.50 min
PQ33/20	33.30±0.40	10.45±0.30	22.00±0.40	13.45±0.30	28.00 min	6.3±0.30	20.00 min
PQ33/25	33.30±0.40	12.8±0.30	22.00±0.40	13.45±0.30	28.00 min	8.7±0.30	20.00 min
PQ33/30	33.30±0.40	15.4±0.30	22.00±0.40	13.45±0.30	28.00 min	11±0.30	20.00 min
PQ35/35	35.10±0.40	17.6±0.40	26.00±0.40	14.35±0.30	31.50 min	12.7±0.40	23.50 min
PQ35/20	35.10±0.40	10.4±0.40	26.00±0.40	14.35±0.30	31.50 min	5.9±0.30	23.50 min
PQ40/20	40.50±0.40	10.2±0.40	28.00±0.40	14.90±0.30	36.00 min	5.4±0.40	27.30 min
PQ40/25	40.5±0.40	13.5±0.30	28.10±0.40	14.90±0.30	36.30 min	8.5±0.40	27.50 min
PQ40/27	40.5±0.40	13.5±0.30	28.10±0.40	14.90±0.30	36.30 min	8.5±0.30	27.50 min
PQ40/30	40.50±0.40	15.15±0.40	28.00±0.40	14.90±0.30	36.00 min	10±0.40	27.30 min
PQ40/40	40.50±0.40	20.1±0.40	28.00±0.40	14.90±0.30	36.00 min	14.95±0.40	27.30 min
PQ41/20	41.8±0.40	10.2±0.40	28.00±0.40	14.90±0.30	37.00 min	5.4±0.40	29.00 min
PQ50/50	50.50±0.50	25.2±0.40	32.00±0.40	20.00±0.30	43.50 Min	18.25±0.40	31.50 min

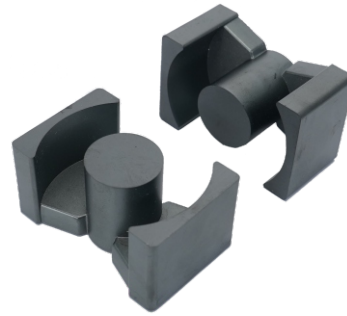
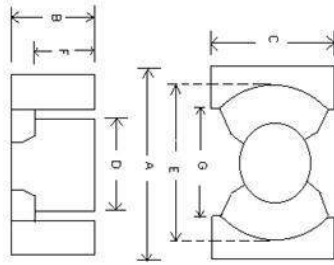

Electrical Characteristics			Material Grades		SFP4, P _V (100kHz, 200mT, 100°C) (W/Set)	SFP95, P _V (100kHz, 200mT, 100°C) (W/Set)
Le	Ae	Ve	AL Values in nH			
mm	mm ²	mm ³	SFP4	SFP95		
34.57	57.60	2017.70	3100±25%	-	≤0.89	-
46.52	62.21	2894.10	3100±25%	3750+30/-20%	≤1.40	≤1.35
38.57	58.60	2251.70	3100±25%	3750+30/-20%	≤1.40	≤1.35
31.36	57.69	1809.00	3100±25%	-	≤0.98	-
30.56	60.84	1859.16	3100±25%	-	≤0.98	-
31.36	57.69	1809.00	3100±25%	-	≤0.98	-
45.20	62.90	2843.00	2650±25%	3300+/-25%	≤1.65	≤1.60
48.30	59.80	2888.40	2650±25%	3300+/-25%	≤1.65	≤1.60
54.70	120.70	6603.90	4500±25%	5700+30/-20%	≤3.75	≤3.60
44.40	122.60	5440.00	5000±25%	6300+/-25%	≤3.20	≤3.00
46.13	111.67	5196.50	5000±25%	-	-	-
46.13	111.67	5196.50	5000±25%	6300+/-25%	≤3.00	-
53.90	113.04	6092.80	5000±25%	6300+/-25%	≤3.00	-
57.90	125.30	7260.00	5000nH±25%	5700+30/-20%	≤3.80	≤3.70
58.65	129.80	7398.00	5000nH±25%	5700+30/-20%	≤3.80	≤3.70
49.15	156.14	7674.50	5400±25%	7600+30/-20%	≤5.50	≤4.70
63.63	161.00	10243.50	5000±25%	7000+/-25%	≤5.20	≤5.00
67.80	153.80	10440.00	4500±25%	6100+30/-20%	≤7.0	≤6.30
73.36	154.00	11298.30	4500±25%	6100+30/-20%	≤6.80	≤6.40
49.15	156.14	7674.50	5400±25%	7600+30/-20%	≤5.50	≤4.70
63.63	161.00	10243.50	5000±25%	7000+/-25%	≤5.80	-
74.60	161.00	11970.00	4500±25%	6100+30/-20%	≤6.80	≤6.40
79.20	169.70	13440.00	4500+30/-20%	5700+30/-20%	≤8.75	≤7.92
57.70	179.30	10351.20	6500±25%	-	≤5.60	-
61.60	203.31	12850.30	6000+/-25%	-	≤6.70	-
70.93	209.46	14857.60	5600+/-25%	-	≤8.74	-
75.28	204.46	15425.60	5600+/-25%	-	≤8.74	-
74.10	190.40	14120.00	5200 +30%/-20%	6500 +30%/-20%	≤ 1.50	≤ 1.45
103.96	191.90	19952.00	4300+30/-20%	5500+30/-20%	≤1.80 @ 100mT	≤1.75 @ 100mT
61.60	203.31	12850.30	6000+/-25%	-	≤6.70	-
115.53	314.40	36356.10	6500+30%-20%	8200+30/-20%	≤3.8 @ 100mT	≤3.6 @ 100mT

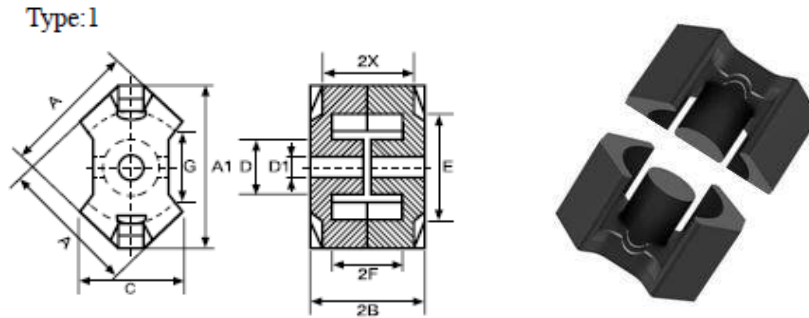

Geometry	Dimensions							
Type	A (mm)	A1 (mm)	B (mm)	C (mm)	D (mm)	E (mm)	F (mm)	G (mm)
RM4	9.60±0.20	10.80±0.20	5.20±0.05	6.40±0.20	3.80±0.10	8.15±0.15	3.60±0.10	-
RM5	12.05±0.25	14.30±0.30	5.20±0.10	9.55±0.25	4.80±0.10	10.40±0.20	3.35±0.20	-
RM6	14.40±0.30	17.60±0.30	6.20±0.10	10.47±0.25	6.30±0.10	12.64±0.25	4.20±0.20	-
RM8	19.35±0.35	22.76±0.45	8.20±0.15	15.45±0.30	8.40±0.15	17.30±0.30	5.60±0.20	-
RM10	24.15±0.55	27.80±0.65	9.30±0.15	19.85±0.30	10.65±0.20	21.65±0.45	6.40±0.20	-
RM12	29.20±0.60	36.85±0.75	12.25±0.10	24.50±0.10	12.60±0.20	25.45±0.55	8.55±0.15	13.40min
RM14	34.80+0/-1.3	42.2+0/-1.2	15.10+0/-0.2	26.80±0.30	15.0+0/-0.5	29.00+1.0/-0	10.4+0.6/-0	17.00min

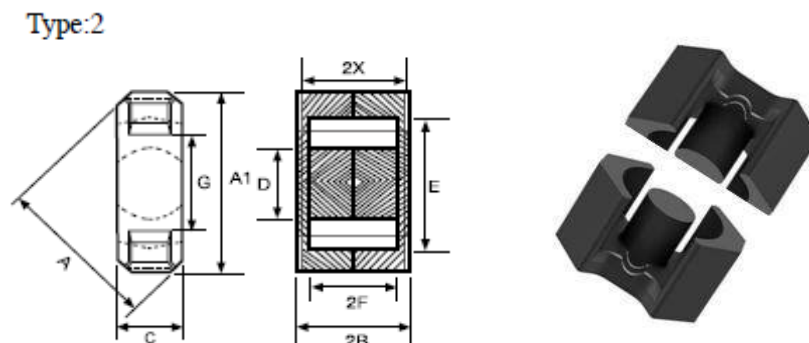

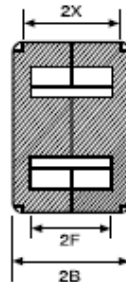
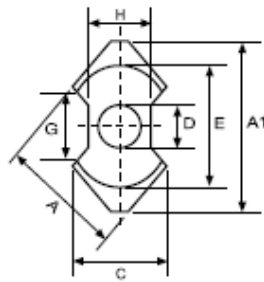
Type:3

Dimensions		Electrical Characteristics			Material Grades			Reference
H (mm)	2X (mm)	Le	Ae	Ve	AL Values (+30/-25%) in nH			Type
		mm	mm ²	mm ³	SFP4	SFA05	SFA12	
-	9.00±0.25	22.0	13.0	286.0	1100	1700	-	1.0
-	9.10±0.25	22.1	23.8	526.0	2000	3500	7500min	1.0
-	10.40±0.25	28.6	36.6	1050.0	2400	4300	7490min	2.0
-	14.40±0.25	38.0	64.0	2430.0	3300	5700	-	1.0
-	16.30±0.25	44.6	96.6	4310.0	4200	7600	-	2.0
15.85±0.25	22.10±0.25	60.6	144.0	8752.0	5550±25%	-	-	3.0
-	27.20±0.25	70.0	200.0	14000.0	6000	-	-	3.0

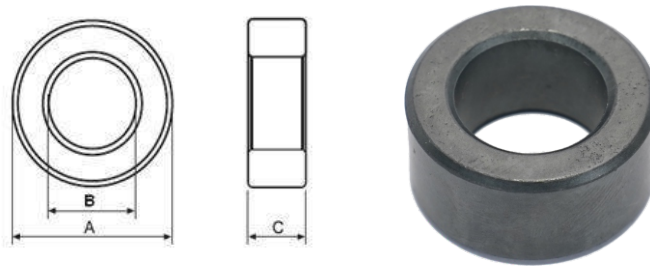

Geometry	Dimensions			
	Type	A (mm)	B (mm)	C (mm)
T6/3/3C		6.0±0.3	3.0±0.3	3.0±0.2
T6/3/3		6.0±0.3	3.0±0.3	3.0±0.2
T6.35/3.81/3.18		6.35±0.3	3.81±0.3	3.18±0.2
T6.35/3.81/3.18		6.35±0.3	3.81±0.3	3.18±0.2
T9/5/3		9.10±0.3	5.10±0.3	3.00±0.3
T9/5/3C		10.0max	4.20min	3.90max
T9.53/4.75/4.8		9.53±0.25	4.75±0.15	4.80±0.15
T9.53/4.75/4.8C		10.38max	4.03min	5.53max
T10/6/4		10.1±0.3	6.1±0.3	4.0±0.3
T10/6/4C		11.00max	5.20min	4.90max
T10/6/5		10.1±0.3	6.1±0.3	5.0±0.3
T10/6/5C		11.00max	5.20min	5.90max
T11.5x7.5x3.6		11.50 ± 0.30	7.50±0.3	3.6±0.3
T11.5x7.5x3.6C		12.40max	6.6min	4.5max
T12.5/7.5/5		12.5±0.3	7.5±0.3	5.0±0.3
T12.5/7.5/5C		13.40max	6.60min	5.90max
T13.3/8.3/5		13.3±0.3	8.3±0.3	5.0±0.3
T13.3/8.3/5C		14.20max	7.40min	5.90max
T14/8/7		14.0±0.4	8.0±0.3	7.0±0.3
T14/8/7C		15.00max	7.10min	7.90max
T16/9.6/6.1		16.0±0.3	9.6±0.3	6.10±0.3
T16/9.6/6.1C		16.90max	8.70min	7.00max
T18/10/7		18.0±0.3	10.0±0.3	7.0±0.3
T18/10/7C		18.90max	9.10min	7.90max
T20/10/7		20.0±0.4	10.0±0.4	7.00±0.3
T20/10/7C		21.0max	9.00min	7.90max
T22/14/6.5		22.0±0.40	14.0±0.40	6.5±0.30
T22/14/6.5C		23.0max	13.00min	7.40max
T22/14/10		22.0±0.40	14.0±0.40	10.0±0.30
T22/14/10C		23.0max	13.00min	10.90max

*C= Coated.

*Customized Dimensions are available.

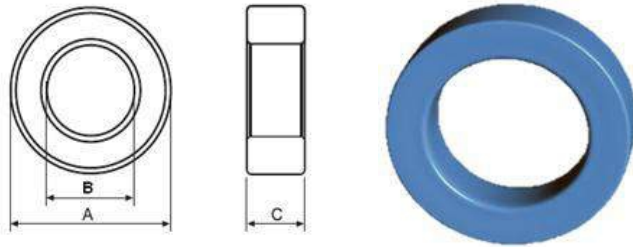

Electrical Characteristics			Material Grades				
Le	Ae	Ve	AL Values ($\pm 25\%$) in nH			AL Values ($\pm 30\%$) in nH	
mm	mm ²	mm ³	SFP4	SFA05	SFA07	SFA10	SFA12
13.1	4.32	56.5	1000	2200	2800	4000	4800
15.3	3.95	60.4	790	1590	2220	3180	3820
20.77	5.83	121.12	880	1760	2470	3520	4060
20.72	11.02	228.28	1670	3340	4680	6680	7720
24.07	7.83	188.44	1020	2040	2850	4080	4900
24.07	9.79	235.55	1270	2550	3570	5100	5820
28.96	7.09	205.33	758	1510	2120	3030	3635
30.09	12.23	368.05	1250	2500	3500	5000	6000
32.70	12.27	401.31	1150	2300	3200	4600	5500
32.82	20.46	671.46	1956	3920	5480	7840	9170
38.52	19.10	735.68	1520	3050	4270	6100	7320
41.55	27.21	1130.43	2054	4110	5760	8230	9600
43.55	33.63	1464.72	2335	4670	6540	9300	11200
54.67	25.56	1397.42	1473	2940	4110	5870	6930
54.67	39.33	2149.88	2259	4520	6330	9040	10670

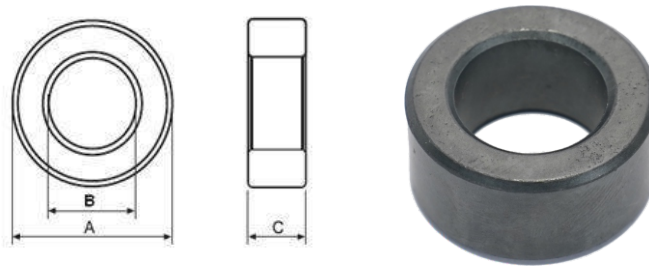

Geometry	Dimensions		
Type	A (mm)	B (mm)	C (mm)
T25/15/10	25.0±0.4	15.00±0.4	10.0±0.30
T25/15/10C	26.0max	14.00min	10.90max
T25/15/13	25.0±0.4	15.00±0.4	13.0±0.3
T25/15/13C	26.0max	14.00min	13.90max
T25/15/15	25.0±0.4	15.0±0.4	15.0±0.3
T25/15/15C	26.0max	14.00min	15.90max
T28/18/16	28.0±0.5	18.0±0.4	16.0±0.3
T28/18/16C	29.1max	17.00min	17.90max
T31/19/13	31.0±0.5	19.0±0.5	13.0±0.4
T31/19/13C	32.10max	17.90min	14.00max
T31/19/16	31.0±0.5	19.0±0.5	16.0±0.4
T31/19/16C	32.10max	17.90min	17.00max
T36/23/15	36.0±0.6	23.45±0.5	15.0±0.4
T36/23/15C	37.20max	22.35min	16.00max
T50/30/20	50.0±1.0	30.0±1.0	20.0±0.50
T50/30/20C	51.6max	28.40min	21max
T55.5/32.6/18	55.5±1.10	32.6±1.10	18.0±0.5
T55.5/32.6/18C	57.20max	30.90min	19.10max
T63/38/25	62.80±1.6	37.60±1.20	25.0±0.6
T63/38/25C	65.00max	35.80min	26.20max
T80/40/15	80.0±1.50	40.0±1.30	15.0±0.6
T80/40/15C	82.10max	38.10min	16.20max
T140/106/25	140.0±3.0	106.0±2.0	25.0±1.0
T140/106/25C	143.80max	103.20min	26.80max

*C= Coated.

*Customized Dimensions are available.

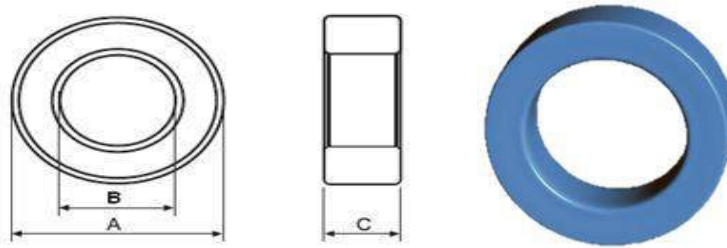

Electrical Characteristics			Material Grades				
Le	Ae	Ve	AL Values ($\pm 25\%$) in nH			AL Values ($\pm 30\%$) in nH	
mm	mm ²	mm ³	SFP4	SFA05	SFA07	SFA10	SFA12
60.18	48.93	2944.42	2550	5110	7150	10220	11000
60.18	63.60	3827.75	3322	6640	9300	13270	15600
60.18	73.30	4416.64	3830	7660	10730	15330	17500
69.96	78.71	5506.49	-	6960	-	-	-
75.49	76.46	5771.89	3180	6360	8910	12730	14500
75.49	94.11	7103.86	3840	7685	10760	15200	18400
89.65	95.89	8595.89	3210	6430	9000	12860	14500
120.36	195.71	23555.40	5000	10000	12250	17300	-
132.07	201.31	26585.86	4683	9365	13100	18730	-
152.09	305.93	46528.26	6200	12500	17700	24770	-
174.21	288.70	50218.93	5200	-	-	-	-
381.00	422.00	160782.00	2750	5550	8750	-	-

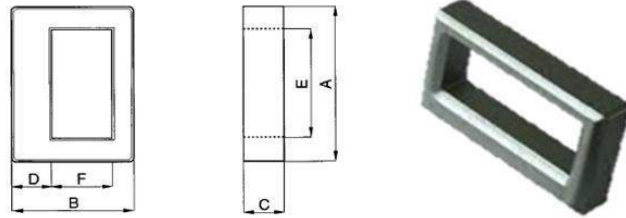

Geometry	Dimensions					
Type	A (mm)	B (mm)	C (mm)	D (mm)	E (mm)	F (mm)
UT20	20.60±0.30	14.10±0.25	4.60±0.20	4.10±0.20	15.70min	7.35min
UT25	25.60±0.40	17.60±0.30	5.20±0.25	5.20±0.15	19.30min	8.70min
UT30	30.00±0.40	19.80±0.30	6.40±0.25	6.40±0.15	22.40min	8.90min

UU Cores

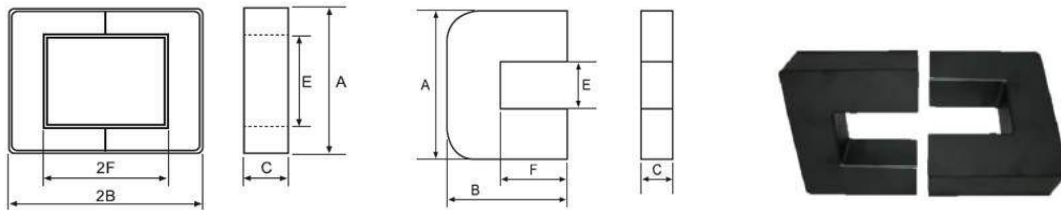

Geometry	Dimensions					Electrical Characteristics		
	Type	A (mm)	B (mm)	C (mm)	E (mm)	F (mm)	Le mm	Ae mm ²
UU9.8 (L)	9.80±0.30	7.10±0.30	2.70±0.30	4.20min	4.30±0.30	34	8	271.11
UU10.5 (L)	10.50±0.30	8.00±0.30	5.00±0.15	5.50min	5.50±0.30	40	13	518
UU93/76/16	93±1.8	76±0.5	16±0.5	34.6min.	48±0.9	354	448	159000
UU93/76/20	93±1.8	76±0.5	20±0.5	34.6min.	48±0.9	354	560	198000
UU93/76/30	93±1.8	76±0.5	30±0.6	34.6min.	48±0.9	354	840	297000
U101/76/30	101±1.8	76±0.5	30±0.6	44.0min.	48±0.9	368	840	310800
U141/78/30	141±4	78.5±0.5	30±1	50min.	33.5±1	377	1350	508950

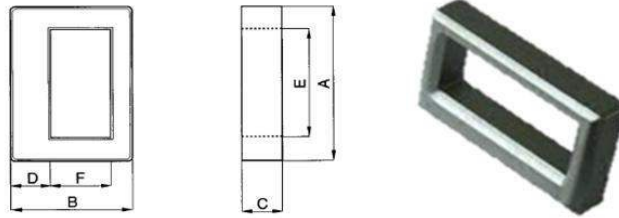

Electrical Characteristics			Material Grades		
Le	Ae	Ve	AL Values	AL Values in nH	
mm	mm ²	mm ³	SFA07	SFA10	SFA121
53	13	688	2140±30%	3000±30%	3700±30%
68	18	1203	2350+40%-20%	3350±30%	-
77	27	2068	3150+40%-20%	4500±30%	-

UU Cores

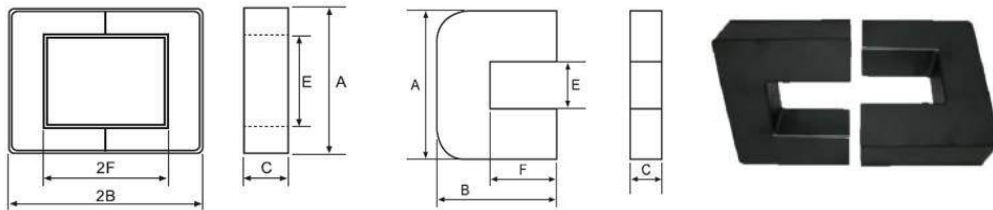

Material Grades					SFP4, P _v (25kHz, 200mT, 100°C) (W/Set)	SFP95, P _v (25kHz, 200mT, 100°C) (W/Set)
AL Values in nH						
SFP4	SFP95	SFA07	SFA10	SFA12		
-	-	≥2500	≥3000	≥3500	-	-
-	-	≥2500	≥3000	≥3500	-	-
3250±25%	4300±25%	-	-	-	≤14	≤9.5
4050±25%	-	-	-	-	≤12	-
6000±25%	-	-	-	-	≤14	-
6000±25%	-	-	-	-	≤14	-
9300±25%	-	-	-	-	≤18	-



Definitions

- 1) Initial Permeability, μ_i
- 2) Effective Permeability, μ_e
- 3) Saturation Flux Density, B_s (T)
- 4) Residual Magnetic Flux Density, B_r (T)
- 5) Coercivity, H_c (A/m)
- 6) Loss Factor, $\tan\delta$
- 7) Relative Loss Factor, $\tan\delta/m$
- 8) Hysteresis Material Constant, ηB ($10^{-6}/mT$)
- 9) Temperature Coefficient, a_v (K^{-1})
- 10) Relative Temperature Coefficient, a_{vr} (K^{-1})
- 11) Curie Temperature, T_c ($^{\circ}C$)
- 12) Resistivity, ρ (Ωm)
- 13) Density, d (kg/m^3)
- 14) Power Loss density, P_c (kW/m^3)
- 15) Inductance Factor, A_L (nH/N^2)

Equations

- 1) μ_i (Initial Permeability)
- 2) Toroidal Permeability
- 3) μ_e Effective permeability
- 4) A_L Inductance Factor
- 5) H Magnetic Field Strength
- 6) Peak AC Flux Density
- 7) L_e Effective Magnetic Path Length of Toroidal Cores
- 8) A_e Effective Cross-sectional Area
- 9) Q Quality Factor

Definitions

1) Initial Permeability, μ_i

This is the limit value of B/H where H is indefinitely close to zero at the initial magnetization curve of a ferromagnetic substance.

$$\mu_i = \frac{1}{\mu_0} \lim_{(H \rightarrow 0)} \frac{B}{H}$$

Where	μ_0	Permeability in Vacuum ($4\pi \times 10^{-7} H/m$)
	H	Magnetic Field Strength (A/m)
	B	Magnetic Flux Density (T)

2) Effective Permeability, μ_e

Effective Permeability of a core forming a closed circuit where leakage flux is negligibly small.

$$\mu_e = \frac{L_e}{\mu_0 A_e N^2}$$

Where	L	Self Inductance of Coil with Core (H)
	N	Number of Turns in Coil
	L_e	Effective Magnetic Path Length of Core (m)
	A_e	Effective cross sectional area of Core (m^2)

3) Saturation Flux Density, B_s (T)

Saturation flux density is the maximum attainable flux density when a very high magnetic field is applied to a soft magnetic material as shown in the figure below.

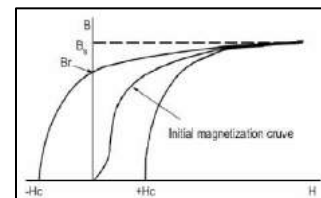



4) Residual Magnetic Flux Density, Br (T)

This is the amount of residual magnetic flux density retained by the core after the magnetic field is weakened and finally removed, as shown in the figure above.

5) Coercivity, Hc (A/m)

This is the strength of the magnetic field whereby the residual flux density becomes zero under the intensification in the opposite direction of the magnetic field, as shown in the figure above.

6) Loss Factor, tanδ

The loss factor can be split up into three parts as $\tan\delta = \tan\delta_h + \tan\delta_e + \tan\delta_r$

Where	$\tan\delta_h$	Hysteresis loss
	$\tan\delta_e$	Eddy-current loss
	$\tan\delta_r$	Residual loss

7) Relative Loss Factor, $\tan\delta/\mu_i$

This is the amount of loss per unit permeability and is defined as below.

$\tan\delta/\mu_i$ (for magnetic material)

$\tan\delta/\mu_e$ (where gaps are added to the magnetic circuit)

8) Hysteresis Material Constant, ηB ($10^{-6}/mT$)

Hysteresis material constant characterizes the change of the hysteresis loss of the material when the flux density is increased.

$$\eta B = \frac{\Delta \tan\delta}{\mu_e \Delta B}$$

Where	$\tan\delta$	Loss factor
	μ_e	Effective Permeability
	B	Magnetic Flux Density (mT)

9) Temperature Coefficient, a_μ (K^{-1})

This is the fractional difference of permeability per °K in a temperature range from T_1 to T_2 ($T_2 > T_1$)

$$a_\mu = (\mu_2 - \mu_1) / \mu_1 (T_2 - T_1)$$

Where	μ_1	Permeability at temperature T_1
	μ_2	permeability at temperature T_2

10) Relative Temperature Coefficient, $a_{\mu r}$ (K^{-1})

This is the temperature coefficient per unit permeability

$$a_{\mu r} = (\mu_2 - \mu_1) / \mu_1^2 (T_2 - T_1)$$

The temperature coefficient of an actual core is obtained from below

$$a_{\mu r} = a_{\mu r} \times \mu_e$$

11) Curie Temperature, Tc (°C)

The Curie temperature Tc is defined as the temperature at which the magnetic core changes from the ferromagnetic to the paramagnetic state.

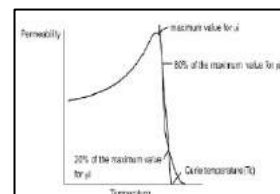



12) Resistivity, ρ (Ωm)

This is the electrical resistance per unit length and cross-sectional area of a magnetic core.

13) Density, d (kg/m^3)

This is the weight per unit volume of a magnetic core.

$$d = W/V$$

Where	W	Weight of magnetic core (kg)
	V	Volume of magnetic core (m^3)

14) Power Loss density, P_c (kw/m^3)

Power loss denotes the loss under a magnetization condition featuring a high frequency and a large amplitude. Operating magnetic flux density is generally expressed for a sinusoidal wave as below.

$$B_m = E/(4.44f NA_e)$$

Where	B_m	Peak value of magnetic flux density (T)
	E	Voltage effective value applied to test coil (V)
	f	Frequency (Hz)
	N	Number of coil turns
	A_e	Effective cross-sectional area of core (m^2)

15) Inductance Factor, AL (nH/N^2)

$$A_L = L/N^2$$

Where	A_L	Self-inductance of coil with core (H)
	N	Number of coil turns

The inductance factor is generally united by $10^{-9}H/N^2$ (nH/N^2)

Equations

1) μ_i (Initial Permeability)

$$\mu_i = \frac{1}{\mu_0} \lim_{(\Delta H \rightarrow 0)} \frac{\Delta B}{(\Delta H)} \quad \mu_0 \quad (4\pi \times 10^{-7} \text{ H/m})$$

2) Toroidal Permeability

$$\mu_i = \frac{1000L \cdot I_e}{4\pi N^2 A_e}$$

Where	L	Inductance(μH)
	μ	Permeability
	N	No of Turns
	A_e	Effective cross sectional area (cm^2)
	I_e	Effective Magnetic Path Length (cm)



3) μ_e Effective Permeability

$$\mu_i = \frac{1000L}{4\pi N^2} \quad \Sigma = \frac{l}{A}$$

Where

- L Inductance(μ H)
- μ Permeability
- N No of Turns
- l Effective Magnetic Path Length (cm)
- A Effective cross sectional area (cm^2)

4) A_L Inductance Factor

$$A_L = L/N^2$$

A_L : nH/N² Inductance Factor

Where

- L Inductance
- N No of Turns

5) Magnetic Field Strength

$$H = \frac{0.4\pi NI}{l_e}$$

Where

- H Magnetic Force(Oe)
- N No of Turns
- I Current(A)
- l_e Effective Magnetic Path Length (cm)

6) Peak Ac Flux Density

$$B_{\max} = \frac{E_{\text{rms}} 10^8}{4.44f A_e N}$$

Where

- B Peak Ac Flux Density (Gauss)
- F Frequency (Hz)
- A_e Effective Cross-Sectional Area cm^2
- E_{rms} RMS Voltage (V)

7) l_e Effective Magnetic Path Length of Torodial Cores

$$l_e = \frac{\pi(OD-ID)}{\ln\left(\frac{OD}{ID}\right)}$$

Where

- OD Outer Diameter (cm)
- ID Inner Diameter (cm)
- l_e Effective Magnetic Path Length (cm)

8) A_e Effective Cross-Sectional Area

$$A_e = \frac{(OD-ID)^2}{2} \times Ht \times K$$

Where

- OD Outer Diameter (cm)
- ID Inner Diameter (cm)
- Ht Height (cm)
- K Coefficient Relative to the Shape of the edges

9) Quality Factor (Q)

$$Q = \frac{\omega L}{R_{dc} + R_{ac} + R_{cd}}$$

Where

- Q Quality Factor
- L Inductance (H)
- $\omega = 2\pi$ Frequency (Hz)
- R_{dc} Dc Winding Resistance (Ω)
- R_{ac} Resistance due to core loss (Ω)
- R_{cd} Resistance due to dielectric loss of Winding (Ω)



QMS



EMS

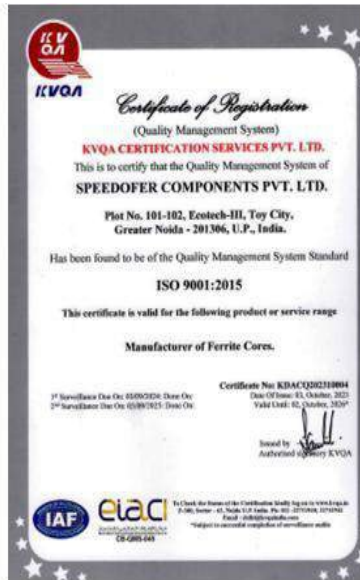

OHSAS

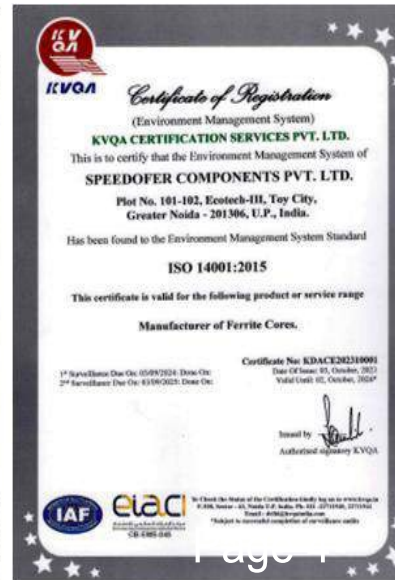

DSIR R&D Recognition



DUNS Number

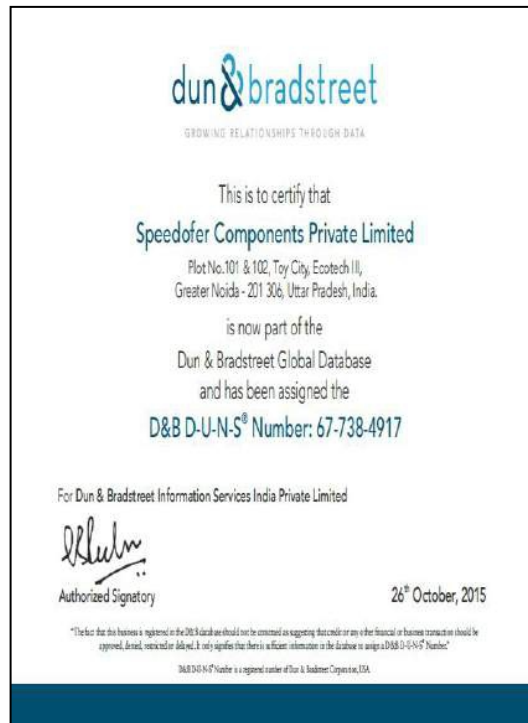

Mr. Randhawa B Singh:



Chairman & Managing Director of Speedofer Components Pvt. Ltd., Bramhajeet Singh Randhawa is an entrepreneur who has over 3 decades of experience in Soft Ferrite Cores Industry.

Forayed into Soft Ferrite Cores manufacturing by setting up Speedofer Components Pvt. Ltd. in 2007 which has an expanded unit and a factory in Greater Noida, India.

Has a vision to grow together with the Clients and take Employees, Business Partners and Suppliers along to make Speedofer most reliable global supplier.

Found Hob-Nob Electronics Pvt. Ltd. in New Delhi in 1994 as an authorized Distributor to EPCOS Ferrite Cores in India.

An Executive Committee member of ELCINA that represents Electronics Industry.

Reachable at bsr@speedofer.com

Mr. Ambar N Sinha:



Former Executive Director of Speedofer Components Pvt. Ltd., Ambar N Sinha was the Managing Director of EPCOS, India. Over 15 years association with EPCOS and built up the company from scratch into a world class manufacturing facility for Soft Ferrites Cores. It is because of the rapid growth of EPCOS that the Indian Ferrite Industry is thriving today.

Graduated from IIT - Kharagpur, has techno-commercial backgrounds and evolved Six Sigma, TPM, Lean Manufacturing processes across the Organizations he served.

Motivates his colleagues by extending his expertise in Business Excellence & Strategies and ever helpful in systematic operations.

Reachable at ssb@speedofer.com

Mr. Probal Mukherjee:



Former Technical Head of Speedofer Components Pvt. Ltd., Mr. Mukherjee was General Manager, R&D in EPCOS, India.

Actively associated with Speedofer Components Pvt. Ltd. in the field of Quality, Customer Support and customized instruments for testing different applicable characteristics of Ferrites Cores.

Graduated from IIT - Kharagpur, who also has wide global experience with having worked in Far East, Europe and the Americas.

Member and Convenor of IEC for standardisation.

Reachable at application@speedofer.com



Speedofer Components Pvt. Ltd.

Plot No. 101 & 102, Toy City, Ecotech III, Greater Noida-201306
Gautam Buddha Nagar, Uttar Pradesh, India



info@speedofer.com



www.speedofer.com



+91 120 4752457